

# VECTOR PCX

## OPERATORS MANUAL

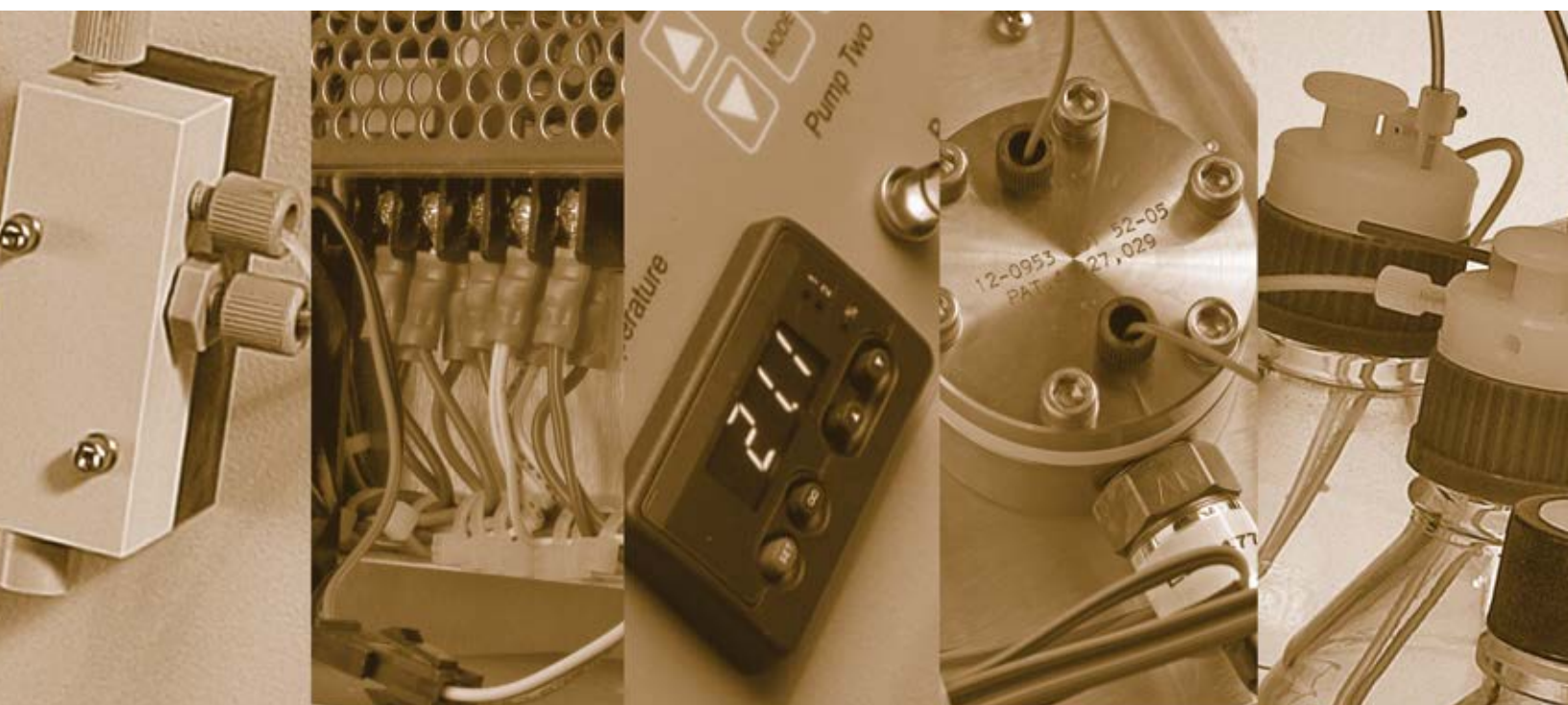

**PICKERING**  
LABORATORIES





# OPERATOR MANUAL

---



**Post-Column  
Derivatization  
Instrument**



1280 Space Park Way  
Mountain View  
CA 94043  
USA

800-654-3330 • 650-694-6700

650-968-0749 FAX

[www.pickeringlabs.com](http://www.pickeringlabs.com)  
[support@pickeringlabs.com](mailto:support@pickeringlabs.com)  
[www.pickeringlabs-retentiontimes.com](http://www.pickeringlabs-retentiontimes.com)

Cat. No. 0101-0009

Rev. H, December 2014

Copyright © 2006 by Pickering Laboratories, Inc. All rights reserved. No Portion of this manual or any artwork contained herein may be reproduced in any shape or form without the express written consent of Pickering Laboratories, Inc.



# TABLE OF CONTENTS

---

## **1 Getting Started**

---

- Read this First! 1
- Symbols and Warnings 1
- Specifications 2
- Site Requirements 4

### **1.1 Section 1 Introduction**

---

- What is Post-column Derivatization? 1
- Requirements for a Successful Post-Column Method 2
- Design of an HPLC System 3
- Designing a Post-Column System 5
- Design of the Vector PCX 6

### **2.1 Section 2 Overview**

---

- Parts Identification/Definition 2.1
- Pressure Switch 2.2
- Reagent Pumps 2.2
- Standard Dual Pump Flow Diagram 2.3
- Standard Single Pump Flow Diagram 2.4
- Polyether Antibiotics Flow Diagram 2.5
- Tricothecene Flow Diagram 2.6
- Prime/Purge Valves 2.8
- Mixing Manifolds 2. **AMPA** 8
- Reactors 2.9
- Control/Display Panel 2.9
- Reagent Reservoirs 2.10
- Detector Connections (100 psi Back Pressure Regulator) 2.10
- Internal Components 2.10
- Power 2.11
- Standard Configurations of Vector PCX 2.12

**3.1** *Section 3* **Installation and Operation**

---

Site Requirements	3.1
Instrument Unpacking and Preparation	3.3
Pump and Autosampler Connections	3.3
Priming of Eluants	3.5
Column and Guard Installation	3.5
Detector Connections	3.5
Gas Connections	3.6
Reagent Pump Preparation	3.6
Basic Start-up	3.8
Over Pressure Relief Valve Connection	3.9
Chromatograms	3.9
Shutdown	3.9
Changing Reagents	3.10

**4.1** *Section 4* **Vector Maintenance**

---

Pump Maintenance	4.1
Replacement of Reagent Filter	4.7
Replacement of the Heated Reactor	4.7
Fuse and Battery Replacement	4.8
Maintenance Schedule	4.9

---

## 5.1 *Section 5* Troubleshooting

---

- Contact Pickering Laboratories for Support 5.1
- Instrument Parameter Log 5.2
- General Troubleshooting Advice 5.2
- Common System Problems 5.4
- Common Column Problems 5.5
- Application Specific Troubleshooting 5.6
- Reagent Pump Troubleshooting 5.6
- Common Chromatography Problems 5.7
- Procedures 5.7

## 6.1 *Section 6* Applications

---

- Carbamates 6.1-1
  - Introduction 6.1-1
  - Background 6.1-1
  - Basic Sample Preparation 6.1-3
  - Reagent Preparation 6.1-4
  - Post-column Conditions 6.1-6
  - Analytical Procedure 6.1-6
  - Sample Chromatograms and Gradient Programs 6.1-6
  - Precautions for Carbamate Analysis 6.1-11
- Glyphosate 6.2
  - Introduction 6.2
  - Background 6.2-1
  - Basic Sample Preparation 6.2-1
  - Reagent Preparation 6.2-2
  - Analytical and Post-column Conditions 6.2-4
  - Analytical Procedure 6.2-4
  - Sample Chromatograms 6.2-5
  - Precautions to be Aware of in Glyphosate Analysis 6.2-6
- Amino Acids 6.3
  - Introduction 6.3
  - Background 6.3-1
  - Basic Sample Preparation 6.3-2
  - Post Column Conditions 6.3-4
  - Procedure 6.3-5
  - Sample Chromatograms and Gradient Programs 6.3-6
  - Precautions for Amino Acid Analysis 6.3-13

---

## **Appendices**

---

Installation/Operational Qualitication of the Vector PCX 7.2  
Installation/Operational Qualification of the Vector PCX Data Sheet 7.4  
Vector Operational Qualification 7.5  
Performance Qualification of the Vector PCX Data Sheet 7.6  
Parts List for Vector PCX 7.12  
References 7.13

## **Index**

---

# GETTING STARTED

---

- 1 Read this first!
- 1 Symbols and Safety Warnings
- 2 Specifications
- 4 Site Requirements

## Read this First!

Before attempting to install the Vector PCX post-column derivatization instrument, it is vitally important that you read this manual first, and attend to site, HPLC, and accessories requirements:

HPLC – Page 4

Gas Supply Requirements – Page 4

Reagent Reservoir bottles – Page 4



## Symbols and Warnings

Caution – this symbol indicates that caution must be used when dealing with this part. In the Vector PCX this symbol indicates that it is possible to receive an electrical shock when dealing with this part. Use caution and always remove the source of power before performing any maintenance in these areas.

To prevent electric shock, always disconnect the power source and isolate the instrument before accessing the Vector PCX.

If any protective covers were removed for service, always replace them prior to use. Always ensure that all ground wires are connected properly (do not over tighten) after service before the instrument is used.

The Caution symbol can be found in 3 places on the Vector PCX:

1. To the left of the power inlet module on the back of the instrument

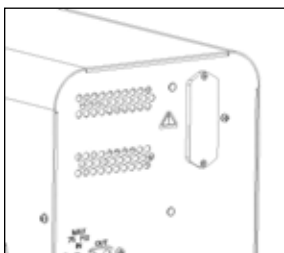

2. On the protective barrier cover inside the instrument (covers high voltage area at rear left of chassis)



3. To the left of the grounding stud behind protective cover

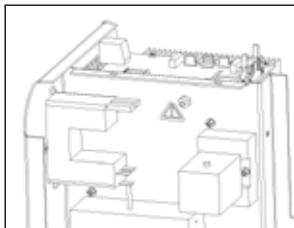

Note: The user shall be made aware that, if equipment is used in a manner not specified by the manufacturer, the protection provided by the equipment may be impaired.

## Specifications

### INSTRUMENT

#### *Dimensions*

16.75 H x 8.75 W x 14.75 D inches (43 x 22 x 38 cm)

#### *Weight*

26 lbs (11.6 kg) for Dual-pump systems

#### *Reagent Pumps*

Max operating pressure 2000 psi (138 bar)

Flow rate range 50 $\mu$ L –2000 $\mu$ L/minute

0.5 % RSD

---

**Heated Reactor**

5°C above ambient to 130°C

Thermal Safety switch limits temperature to 150°C

Stability +/- 0.5°C

Accuracy +/- 1°C

**Electrical**

120 VAC +/- 10%, 240 VAC +/- 10%

2.5 A maximum at 108 VAC

50 – 60 Hz

**Fuses**

2 ea, 5mm x 20 mm, T (time lag) 3.15A

The same fuse is used for both 120V and 240V systems

**Battery**

On the control board for each reagent pump there is a replacement coin cell battery. Use a CR2032, lithium battery, 3-volt, 20 mm diameter, 3.2 mm thick

**ENVIRONMENTAL**

Indoor use only

Altitude up to 6500 ft (1981 m)

Ambient Temperature 5 – 40°C

Relative Humidity up to 80% at 31°C

This device complies with EN 61326:1997/A1: 1998/A2: 2001 emission and immunity specifications for EMC.

**WETTED MATERIALS****Tubing**

PEEK, PTFE FEP, Air Barrier Tubing, Titanium, Borosilicate Glass, Synthetic Ruby, Sapphire, Stainless Steel, Kalrez

## Site Requirements

### INSTRUMENT

#### ***Bench Space***

21 H x 13.75 W x 19 D inches (53 x 35 x 48 cm), with bottles and electrical connections in place.

Minimum 3 inches clearance at back of instrument for venting.

The total space requirement depends on the brand and model of HPLC.

#### Electrical Outlet

One grounded outlet must be provided for the Vector PCX.

#### ***Gas Supply***

High purity Nitrogen, regulated to 45-75 psi.

Outlet of regulator must connect to 1/8" OD tubing.

The maximum gas inlet pressure must not exceed 75psi.

#### ***Reagent Reservoir Bottles***

The Vector PCX includes pressurizable reagent reservoirs.



Caution: For your safety, the bottles are coated with a tough plastic film and rated to a maximum of 15 psig (1 bar). Do not use uncoated bottles.

#### ***HPLC Pump***

Application Dependent; binary gradient for glyphosate, carbamate applications

#### ***Autosampler***

Min injection volume 10 $\mu$ L, preferably by full-loop injection

For drinking water, min injection volume 200 $\mu$ L

Tefzel rotor seal required for all applications using eluants with pH>10

PEEK needle seat required for all applications using eluants with pH>10

---

**Column Oven**

The Vector PCX does not include a column oven. Therefore a column oven is needed to regulate the column temperature to +/- 1°C of the set point.

**Detector**

Pressure rating of flow cell must be > 110 psi

**MISCELLANEOUS SUPPLIES**

If applicable, a Dead-Head Kit may be required to reduce the flush volume of the HPLC and to protect the pressure switch from corrosive eluants. This can be purchased from Pickering Laboratories.

**Chemistry**

The user must check the chemistry requirements for the specific application.

**For Carbamate Analysis**

HPLC Grade Methanol or Acetonitrile

HPLC Grade Water

Materials for calibration standards

Carbamate hydrolysis reagent (Cat. No. CB910)

Carbamate OPA diluent (Cat. No. CB130 or CB130.2)

o-phthalaldehyde (Cat. No. O120)

Thiofluor™ (Cat. No. 3700-2000)

**For Glyphosate Analysis**

5% Sodium hypochlorite solution

Materials for calibration standards

Methanol for OPA reagent preparation

Glyphosate Eluant, pH 2.0 (Cat. No. K200)

Glyphosate Regenerant (Cat. No. RG019)

Glyphosate hypochlorite diluent (Cat. No. GA116)

Glyphosate OPA diluent (Cat. No. GA104)

o-phthalaldehyde (Cat. No. O120)

Thiofluor™ (Cat. No. 3700-2000)



## Section 1

# INTRODUCTION

---

- 1.1 What is Post-column Derivatization?
- 1.2 Requirements for a Successful Post-Column Method
- 1.3 Design of an HPLC System
- 1.5 Designing a Post-Column System
- 1.6 Design of the Vector PCX

### What is Post-column Derivatization?

This is a method which renders visible certain compounds that are normally invisible. Since this reaction occurs after, or post-separation, it is referred to as post-column derivatization. The analytes of interest are separated on the column first, and then reacted with a chemical that will render them detectable at a desirable wavelength, voltage, or any number of various means of detection.

Post column derivatization enhances the sensitivity of HPLC by several means:

- 1) Most reagents are selective for a particular class of substances, so analytes of that class are more easily seen against a complex background.
- 2) Since the separation is performed first, the matrix of the sample is either washed off of the column before the analytes, or is retained by the column. This leaves a very pure sample of analyte to react. This eliminates the need for extensive sample clean-up, and provides a very reproducible reaction because there are no matrix interferences.

The Vector PCX post-column derivatization instrument automatically mixes the stream of effluent flowing from the HPLC column with a stream of reagent solution. The mixture flows through a reactor to allow enough time for the chemical reactions to complete. In many cases, the reaction is very slow at room temperature. For this reason, the reactor can be heated.

There are some methods that require two or more reagents added in sequence. This is done by the addition of a second reagent pump. In many cases, the second reaction occurs at a much faster rate, and can be efficiently accomplished at room temperature.

After the reaction is complete, the derivatives flow into the detector, where the absorbance or the fluorescence (usually) is measured by the HPLC system. These two means of detection are the most common, but they are certainly not the only means of detection.

---

## Requirements for a Successful Post-Column Method

There are many things to take into consideration when developing a method and instrument for post-column derivatization. For example, many pumps have a periodic motion when drawing and dispensing that will manifest itself in the baseline of a chromatogram unless it is properly dampened. Below are the basic requirements for a successful automated post-column method.

- 1) **Reagent Stability.** The minimum reagent stability sufficient for routine work is one day. This means that the yield and signal-to-noise ratio for a given sample must remain constant for at least 8 hours.
- 2) **Reaction Speed.** The analytical separation is complete when the reagent is mixed with the column effluent. Therefore it is important that the analyte react as quickly as possible. The longer the reaction time, the larger the reactor volume required. With larger volumes, the peak shape will become distorted. To minimize band spreading, it is important to keep the overall time (and therefore volume) as low as possible between the column and detector. If the reaction is slow (in excess of one minute), an elevated temperature can be used to decrease the reaction time.
- 3) **Reproducibility.** Because the reaction is occurring “on the fly,” as the combined column and reagent stream flows toward the detector, the reproducibility is linked to the flow rate precision of the pumps and to the temperature. Accordingly, even an incomplete reaction will be as repeatable as the retention time for any given species. Therefore, it is important that the pumps maintain a constant flow rate, and that the reactor maintain a constant temperature. It is also very important that the column be maintained at constant temperature to ensure that the analytes are properly separated and identified.
- 4) **Minimal Detector Response of Reagents.** The color or background fluorescence of the reagent (or its by-products) represents a continuous noise source. Because the reagent is present in excess relative to the analyte, the analyte’s signal could be obliterated by the reagent’s strong background signal. The baseline noise is proportional to the background signal.
- 5) **Solubility.** All species must remain in solution, including the combined components of the eluants and the reagent(s), as well as the newly formed derivative(s). Precipitates can block capillary tubes, burst reactors, and foul detector flow cells.
- 6) **Uniformity of flow.** The baseline noise is a function of the flow-noise in the eluant and reagent pumps. Non-uniform flow causes non-uniform mixing leading to modulation of the background signal which appears as noise. Refractive index noise can be even more objectionable than absorbance noise. Common techniques for evening the flow of the pumps is the addition of a pulse dampener, or the use of a syringe pump. Most modern detectors are not sensitive to refractive index noise.

## Design of an HPLC System

This next section is a simplified view of an HPLC, followed by the ideas behind a post-column system. This section is intended to help novice HPLC operators.

In order to understand post-column HPLC, we need to understand the design of an HPLC. If we connect an HPLC pump directly to a detector (with nothing in between), the baseline from the detector shows a periodic noise (Figure 1-1); the time period is equivalent to the pump stroke.

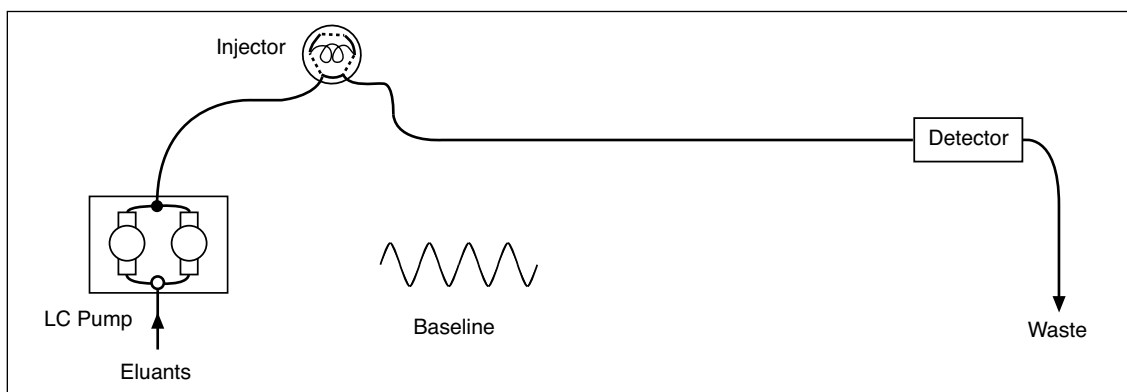

Figure 1-1

Now add a commercial pulse dampener. The baseline is still not smooth; the periodic noise is still there although less pronounced (Figure 1-2). The pulse dampener absorbs most of the pulses from the pump, but the flow requires more stabilization.

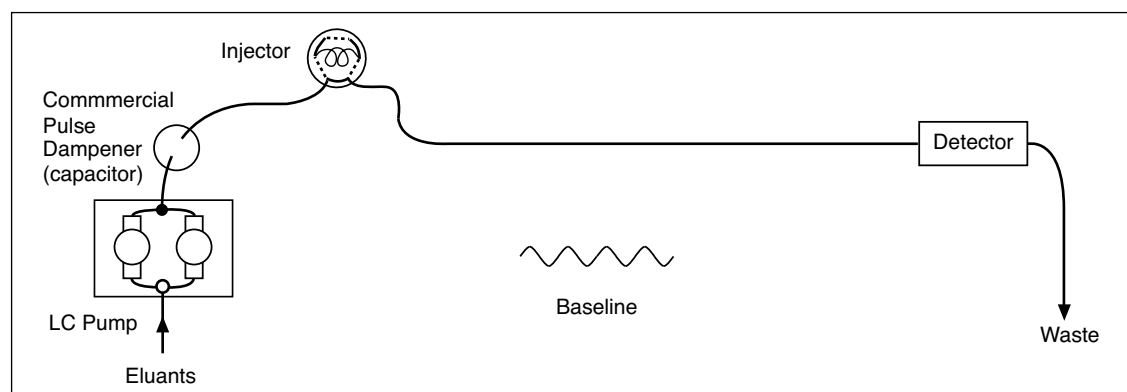

Figure 1-2

A pulse dampener is a capacitor in series with a restrictor. The capacitor is driven by a down-stream pressure drop to store part of the flow during the pressure stroke of the pump; the stored volume is then given up during the refill stroke.

The flow at the outlet of the restrictor will thus be constant. In an HPLC system, this is accomplished with the analytical column. Actually, the column does more than separation; it creates a back-pressure. The combination of the pulse dampener (capacitor) and the column (restrictor) creates a smooth baseline.

(Figure 1-3)

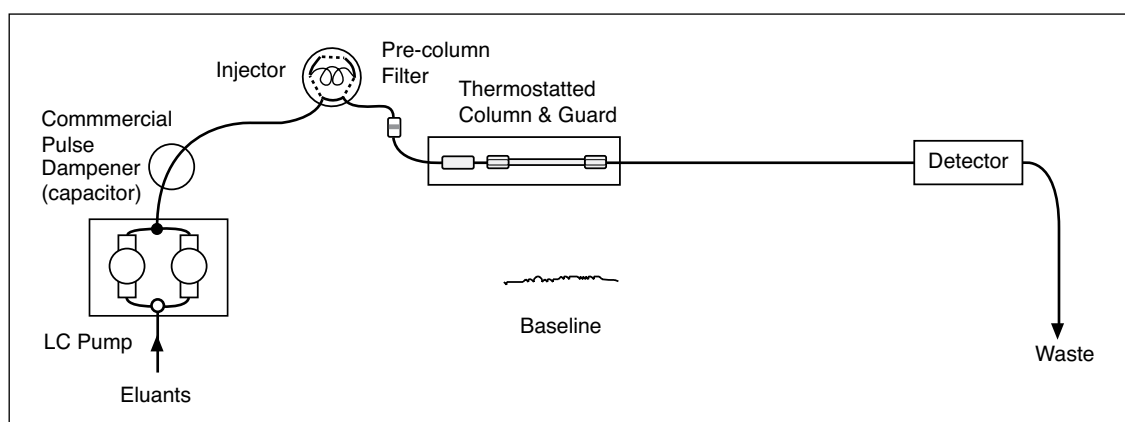

Figure 1-3

An analogy will help us understand the concept. Let us use a river as an example. If it rains; the river swells. If it stops raining; the level goes down. As the level fluctuates, it is equivalent to a periodic noise. To obtain a constant flow, we need to add a reservoir (pulse dampener) and a dam (column). The flow downstream from the dam is constant (smooth baseline).

## Designing a Post-Column System

The same principals that are used in HPLC can be applied to the post-column system. What happens if we simply add a post-column pump, a mixing tee, and a reactor? The periodic noise returns to the baseline (created by the post-column pump; Figure 1-4).

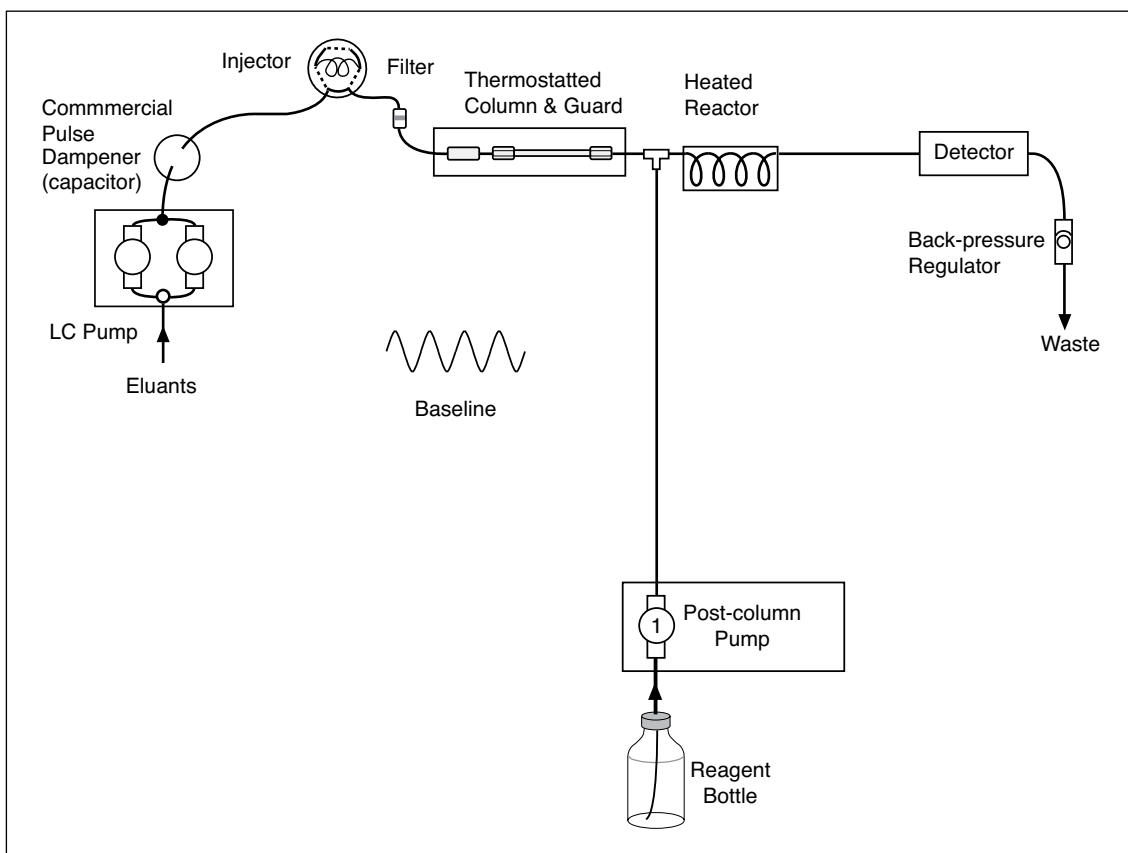

Figure 1-4

Without modification, single-piston, positive-displacement pumps are extremely pulsatile. In a post column system, compositional pulses would be observed at the detector and would result in baseline perturbations. To minimize this noise, a pulse dampener must be used between the reagent pump and the mixing tee.

## Design of the Vector PCX

We do not need to invent anything new; we just need a pulse dampener and a column.

The Vector PCX contains a pulse dampener after the pump and the Pickering “column” is a restrictor packed with inert material. With this “flow conditioner” in place, the baseline is now acceptable.

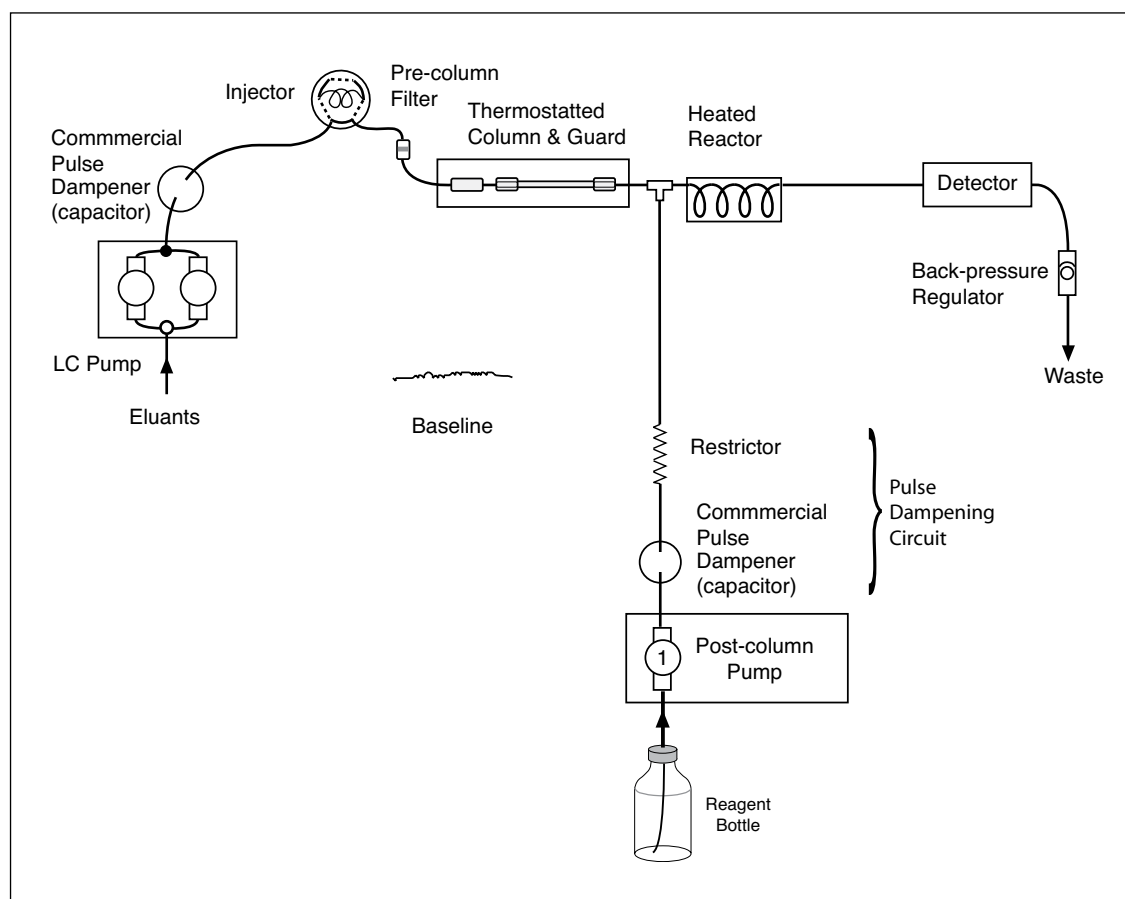

Figure 1-5

NOTE: The term “Pulse Dampener” is a commonly used term and is used throughout this manual for consistency. However, the part many know as “Pulse Dampener” is actually a capacitor. It requires a restriction down-stream to work properly. The Capacitor and Restrictor make up the Pulse Dampening circuit shown above and on page 2.3, figure 2-2.

## Section 2

# OVERVIEW

---

- 2.2** Parts Identification
- 2.2** Pressure Switch
- 2.3** Standard Dual Pump Flow Diagram
- 2.4** Standard Single Pump Flow Diagram
- 2.5** Polyether Antibiotics Flow Diagram
- 2.6** Tricothecene Flow Diagram
- 2.7** Reagent Pumps
- 2.8** Prime/Purge (bypass) Valves
- 2.8** Mixing Manifolds
- 2.9** Reactors
- 2.9** Control/Display Panel
- 2.10** Reagent Reservoirs
- 2.10** Detector Connections
- 2.10** Internal Components
- 2.11** Power
- 2.12** Standard Configurations

This chapter is designed to familiarize you with the components, layout, and function of the Vector PCX. Here you will find descriptions of each key component of the instrument and what it does. At the most basic level, the Vector PCX performs two main tasks:

1. Delivers the reagent in a smooth and consistent manner
2. Heats the reaction

In addition to accomplishing the above two tasks, the Vector PCX has various features to make the analysis more reliable, convenient and simple. It also contains features to protect the instrument from accidental damage.

The flow path of the Vector PCX is extremely inert, rendering it very versatile. The same instrument can be used for many different applications, and will tolerate a high percentage of reagents.

## Parts Identification/Definition

The front panel is the busiest area of the instrument. Everything that you need is located on the front of the panel. Refer to Figure 2-1 for parts identification throughout the next section.

1. Pressure Switch
2. Pump 1
3. Pump 2
4. Prime/Purge Valve 1
5. Prime/Purge Valve 2
6. Mixing Manifold 1
  - Reagent Filter
  - Analytical Column Outlet
  - Heated Reactor Inlet
  - Over pressure Relief Valve
7. Mixing Manifold 2
  - Reagent Filter
  - Heated Reactor Outlet
  - Ambient Reactor Inlet
8. Heated Reactor
9. Ambient Reactor
10. Gas manifold
11. Enable Button
12. Heated Reactor Controller
13. Power Indicator
14. Pump 1 Control Pad
15. Pump 2 Control Pad

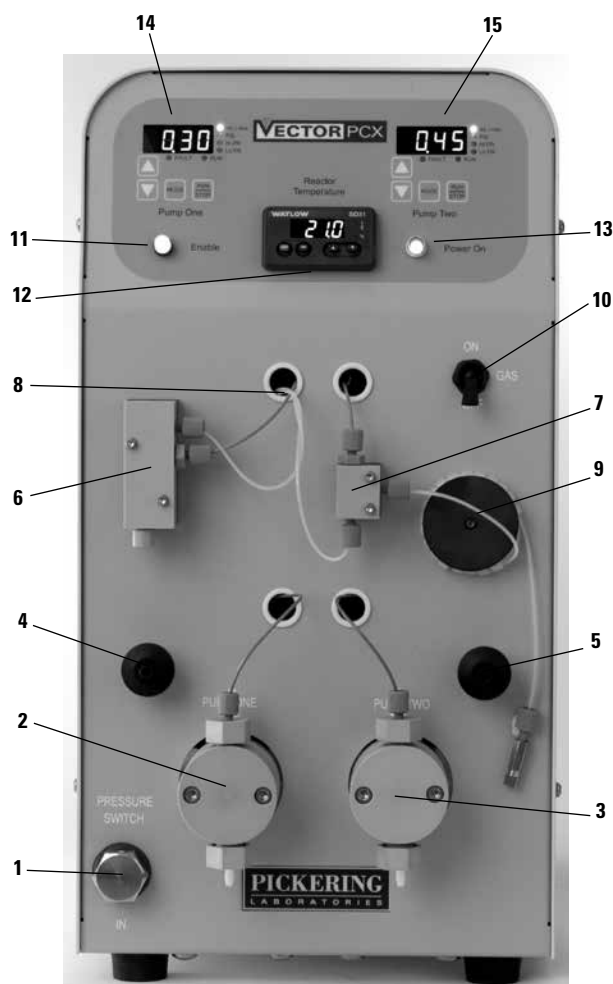

Figure 2-1

## Pressure Switch

The liquid connection (figure 2-2) from the LC Pump to the pressure sensor is at the port labeled “IN” and the connection to the Injector is from the port at the top of the pressure switch. The pressure sensor is part of the safety interlock system. The sensor requires 425 psi (30 bar) before the module can be enabled.

### Standard Dual Pump Flow Diagram

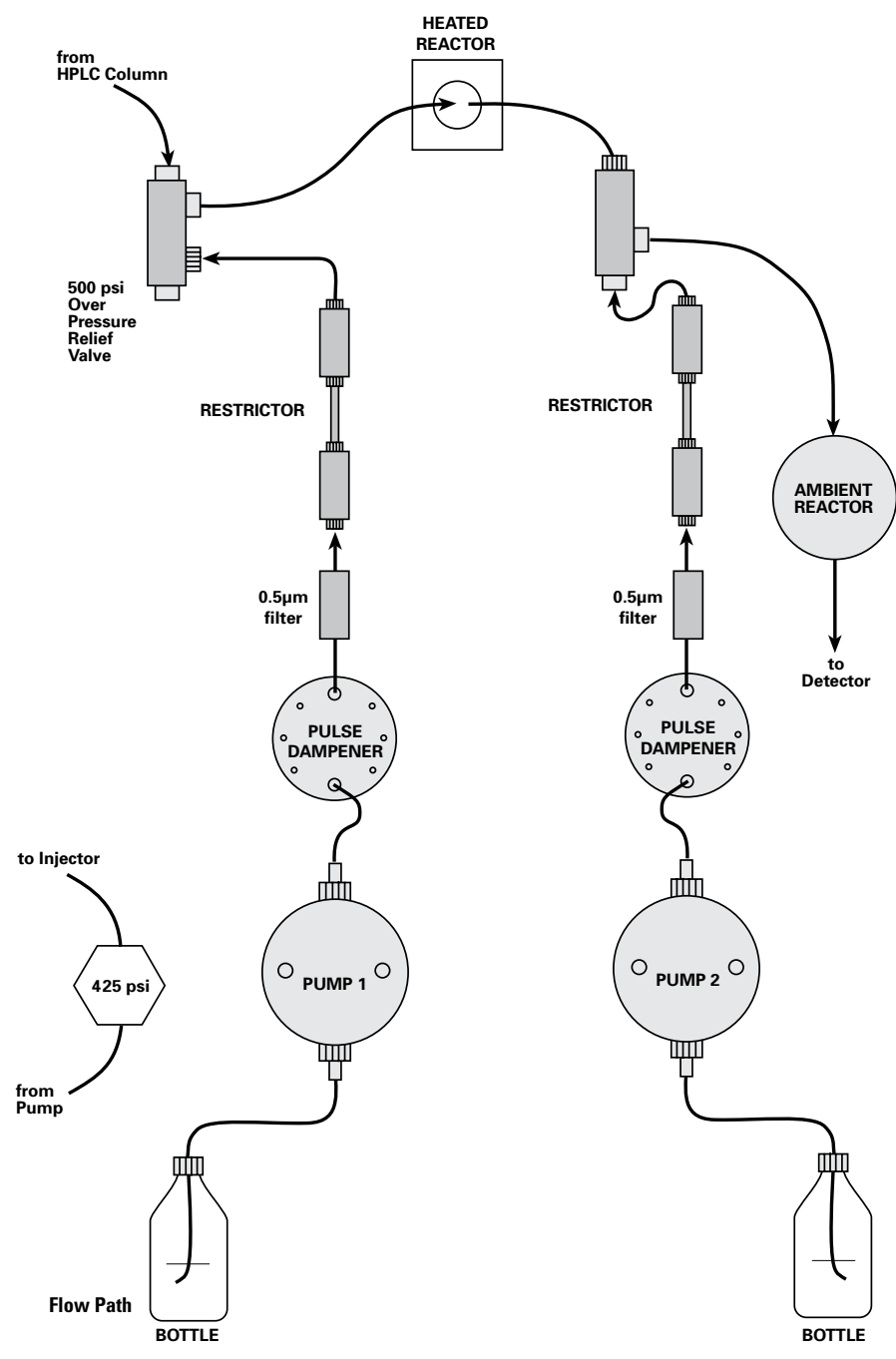
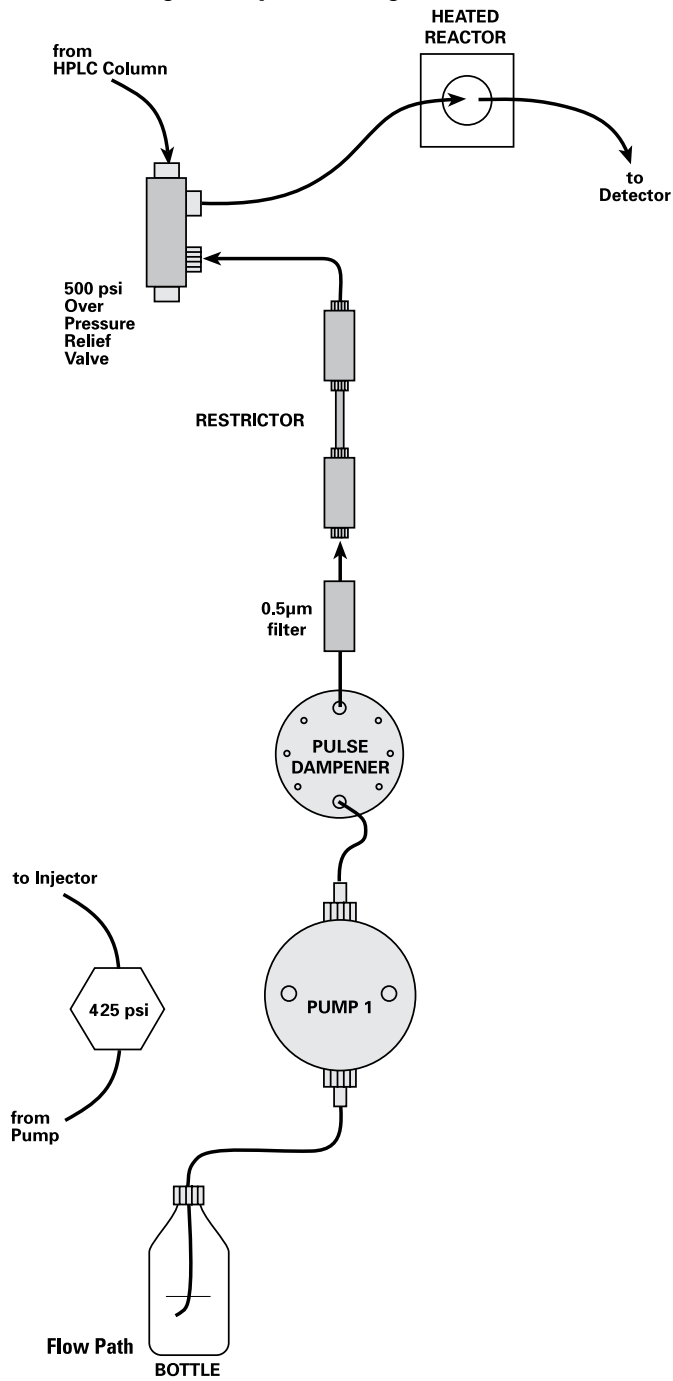
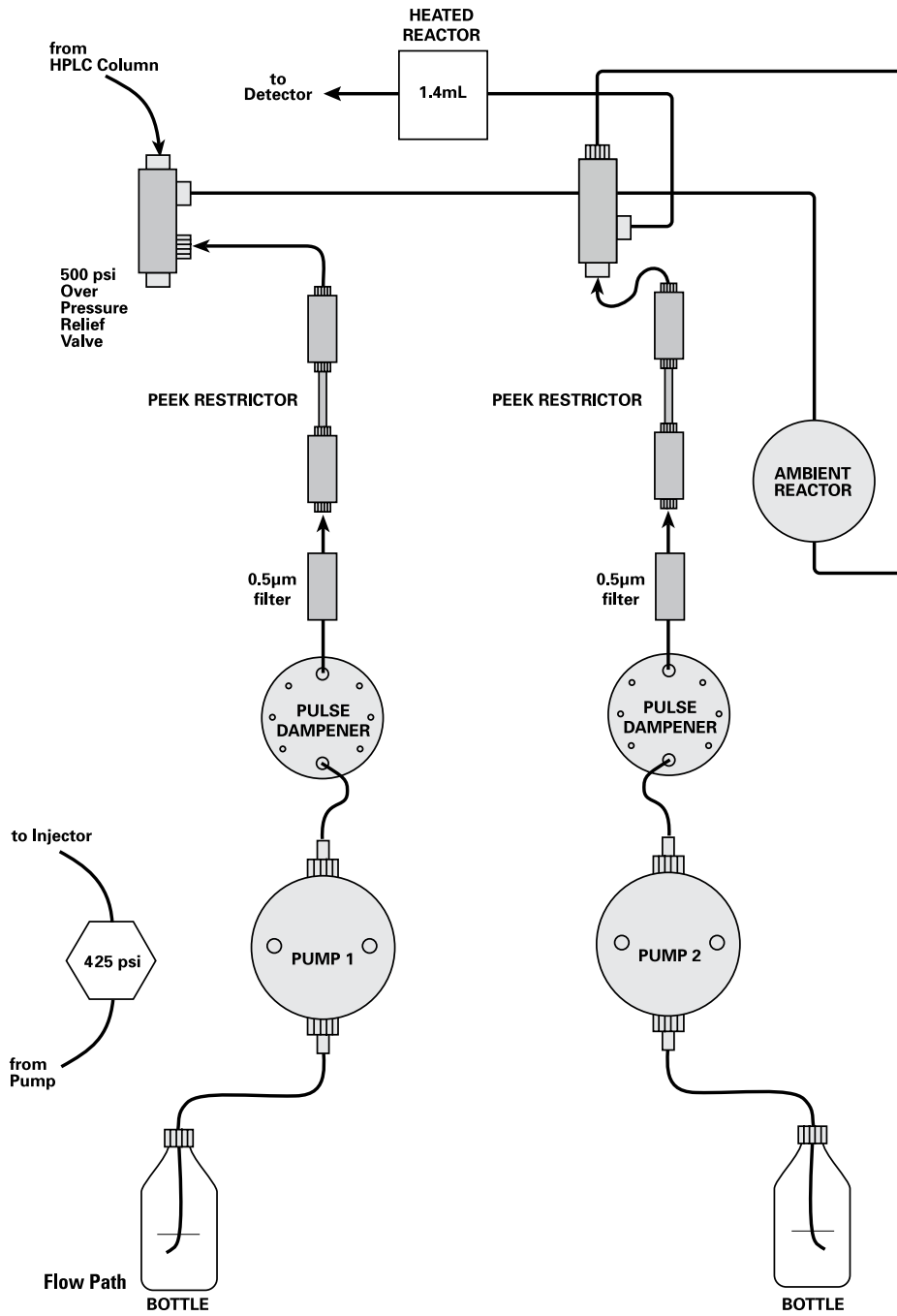

Figure 2-2

### Standard Single Pump Flow Diagram



### Polyether Antibiotics Flow Diagram



### Tricothecene Flow Diagram

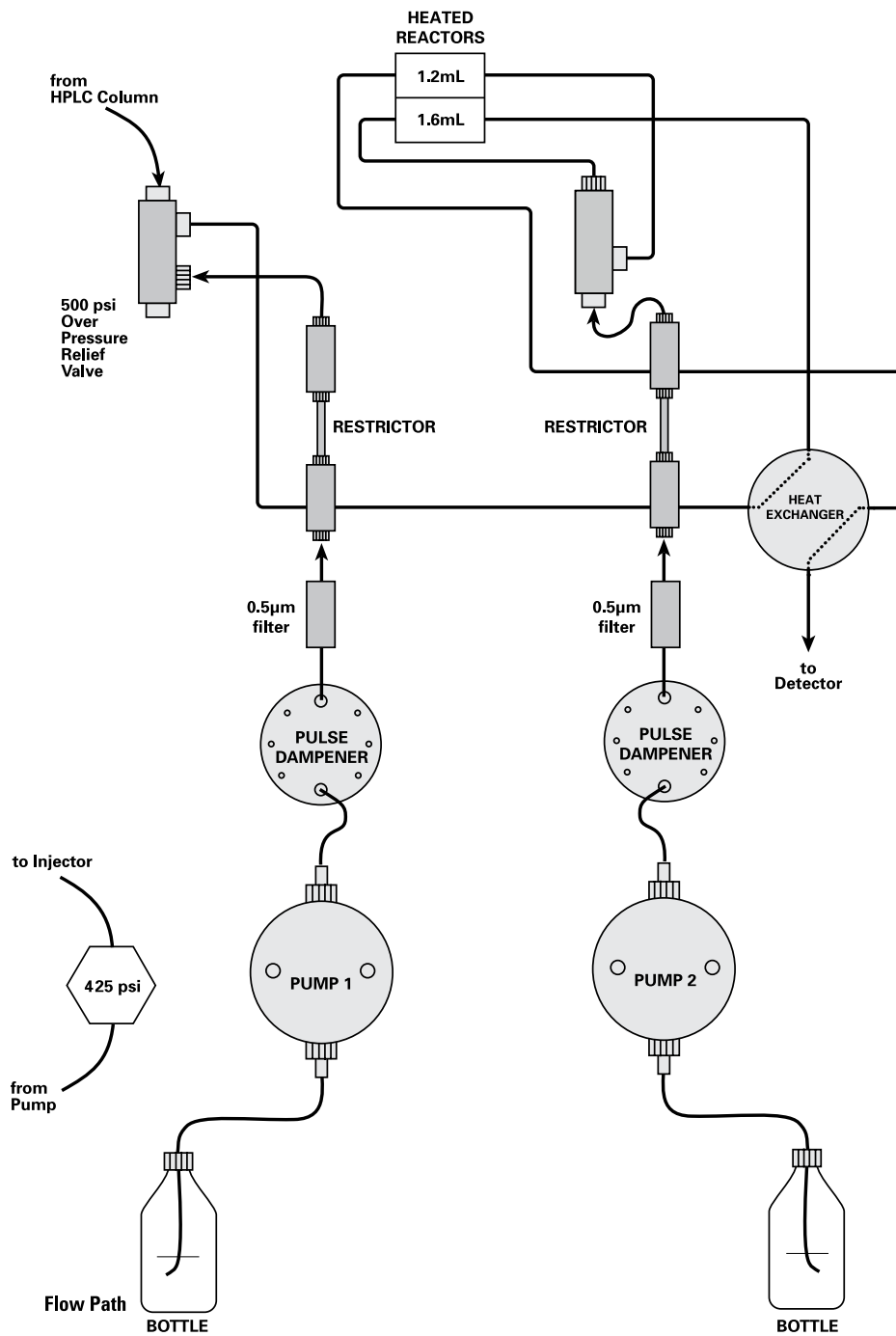

## Reagent Pumps

The liquid end of the reagent pump with a piston-wash system is at the front of the Vector PCX. In normal operation, the pump requires no adjustment. It is set at the factory to 0.30 mL/min for both channels. However, the user can adjust the flow rate at any time. That procedure is described later in this manual.

The flow can be set in 0.01 mL increments from 0.01 to 2.00 mL/min with a precision of 0.5% RSD.

The pump is a reciprocating, single-piston pump with an advanced rapid-refill cam design.

Automatic, self-flushing pump heads (figure 2-3) provide continuous washing of the piston surface without the inconvenience of a manual flush or gravity feed arrangement. The self-flushing pump head uses a diaphragm and secondary set of check valves to create a continuous and positive flow in the area behind the high pressure pump seal. The flushing solution washes away any reagents on the piston. If not removed, these can crystallize and abrade the high pressure seal and cause premature seal failure, leakage, and can possibly damage the pump.

There are pressure maximum and minimum limits which will stop the pump if the pressure exceeds 2000psi or drops below 10psi for more than a minute.

**WARNING:**  
Always release pressure from the pump slowly. A rapid pressure release could cause the pulse damper diaphragm to rupture.

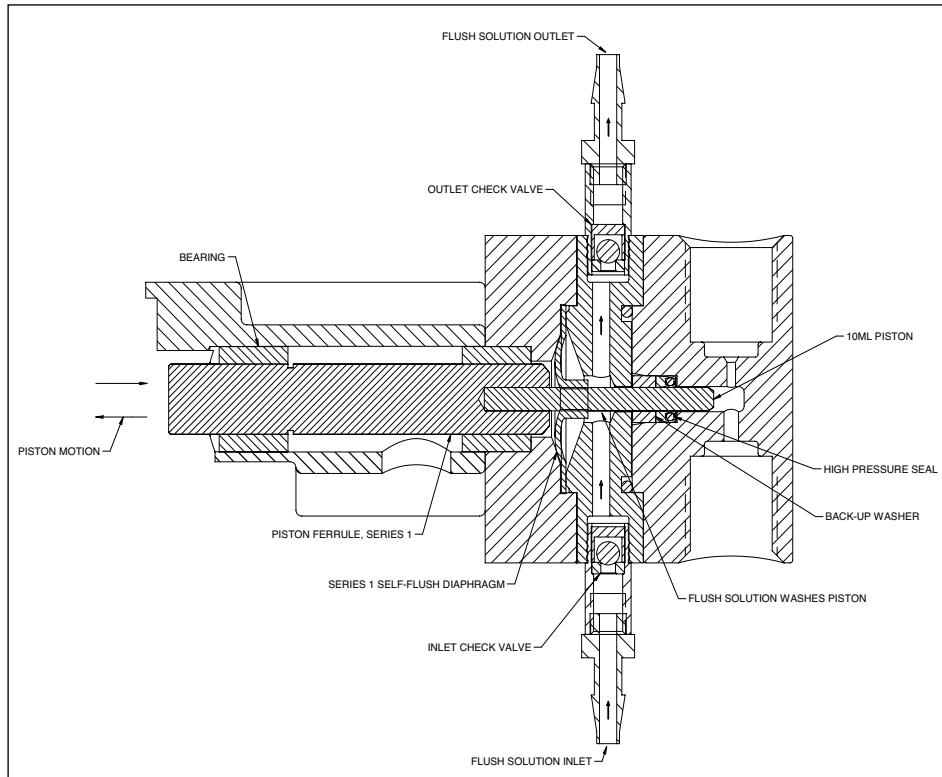

Self-flushing mechanism of Reagent pump

Figure 2-3

---

The self-flush piston wash requires 250-500 mL of 20% methanol in water as a flushing solution. A pH indicator that will indicate the concentration of salts in the solution is recommended as a reminder to change the solution. **This flush solution should be replaced with a fresh solution weekly to avoid frequent pump maintenance.**

Important!

Make sure the piston seals are wetted before turning on the pumps. This is easily accomplished by priming the pump as described in the Operation section of this manual.

## Prime/Purge Valves

The Prime/Purge valves are used to purge and prime the reagent pumps. They are needed to remove air bubbles from the tubing, check valves and pulse dampener.

## Mixing Manifolds

### MANIFOLD 1

This manifold is a mixing tee designed to mix the effluent from the column with the first reagent.

In addition to the ports for samples coming in from column and out to the heated reactor, this manifold contains:

1. Reagent Filter: The reagent filter element is a 10  $\mu\text{m}$  frit located in each of the mixing manifolds. They are disposable and cannot be cleaned.
2. Over Pressure Relief Valve: The Over Pressure Relief valve is a safety relief valve that opens in case the post-column pressure reaches >500 psi. This protects the soft PTFE tubing of the reactors from rupture in the event of a blockage in the post-column system or other fault. Run a piece of tubing from this fitting to a clean dry beaker. Any evidence of liquid in this tubing indicates a fault condition.

### MANIFOLD 2

This manifold is a mixing tee designed to mix the sample from the heated reactor with the second reagent. In addition to the ports coming in from heated reactor and out to the ambient reactor, this manifold contains:

1. Reagent Filter: The reagent filter element is a 10  $\mu\text{m}$  frit located in each of the mixing manifolds. They are disposable and cannot be cleaned.

---

## Reactors

### HEATED REACTOR

The heated reactor is a coiled tubing that can be heated from 5°C above ambient to 130°C. It heats the reaction between Reagent one and the sample. Larger volumes are knitted to reduce band spreading. Volumes greater than 2.0 mL heat to a maximum temperature of 80°C.

### AMBIENT REACTOR

The ambient reactor is a coiled tubing that is at room temperature. It is 100µL in volume. The outlet of this reactor is connected to the inlet of the detector via a zero-dead volume (ZDV) union.

### GAS MANIFOLD

The “Gas Inlet” fitting at the rear of the instrument is where inert gas enters the internal gas regulator for pressurizing the reagent reservoirs. The gas regulator requires an input pressure of 45–75 psi (3–5 bar) to function properly.

Gas is controlled by the toggle valve (No. 10 on figure 2-1). Lever ON allows the flow of gas to the reagent reservoirs.

The manifold has a safety relief valve that opens at about 12 psi to prevent dangerous over-pressurizing of the reagent reservoirs.

Gas tubing for all reservoirs are 1/8” OD Air Barrier Tubing. Just under the cap there is a pinhole drilled in the gas tubing to prevent liquid from creeping up the gas line in case of a slow leak in the gas system. Connect the gas tubing to the gas manifold using 1/4-28 nuts and ferrules.

Each tubing line from bottle to gas manifold has its own check valve to prevent back flow of gas from the pressurized reagent reservoirs.

## Control/Display Panel

The display panel is the information panel of the Vector PCX.

It contains:

1. Display and control pads for adjusting the flow rates and monitoring the pressure of each pump (Items 14 and 15 on Figure 2-1)
2. Displays and control pad for heated reactor temperature or set point (Item 12 on Figure 2-1)
3. Enable Button (Item 11 on Figure 2-1). An Orange LED that is illuminated when there is 500psi of pressure reading on the Pressure Switch. Used to bring up the pump and reactor displays, and also start heating the reactor prior to turning on the reagent pumps.
4. Power indicator (Item 13). A Green LED that is illuminated when power is going into the Vector PCX.

## Reagent Reservoirs

The Vector PCX includes two pressurized reagent reservoirs.

The pressurized reagent reservoir serves two purposes:

1. It protects the air-sensitive reagents from oxidation
2. It helps the reagent pump fill consistently and quickly by providing a source of pressure.

The reservoir cap has a built-in vent valve. The large white knob is the valve; pull it up for CLOSED, and push it down for OPEN. If the gas is turned on, opening the vent valve will sparge the reagent. Closing the valve will pressurize the reservoir; this is the normal operating position. On the side of the cap, away from the on-off valve, there is a 1/4-28 fitting; you may optionally connect a tube here to carry vapors to an exhaust vent.

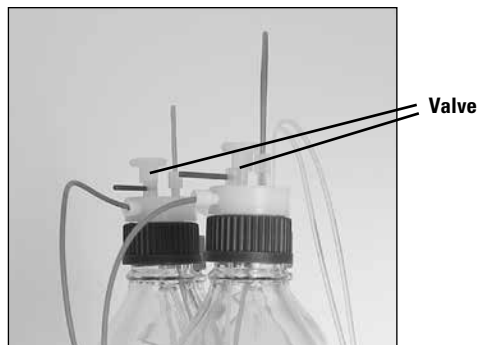

At the top of the cap, in line with the tubing feeding the pump, there is a blue lever. This is the reagent open/close valve. Turning the lever perpendicular to the tubing closes the valve. This is used for vacuum priming and for storing pressurized reagent under inert gas. See the Troubleshooting section for information on vacuum priming.

## Detector Connections *(100 psi Back Pressure Regulator)*

There is a 100psi (7bar) back-pressure regulator on the exit line from the detector; it suppresses boiling inside the hot reactor and prevents bubbles from forming in the detector flow cell. This in turn provides for a smooth baseline and therefore high-sensitivity.

The union at the outlet of the ambient reactor should be connected to the detector with 0.010 inch (0.25 mm) ID tubing.

## Internal Components

The removable cover gives access to the motor ends of the pumps, restrictors, 0.5µm filters, heated reactor, electrical connections, gas regulation system and pulse dampeners

The only time you will need to access the inside is for restrictor replacement, 0.5µm filter replacement or heated reactor replacement. The pump seals can be replaced externally without having to remove the Vector PCX cover.

---

The standard reactor is a PTFE capillary tube 0.010" I.D. wrapped on a heated mandrel. The narrow diameter reduces band-spreading, and the PTFE is corrosion resistant. The reactor can be easily switched if it becomes blocked or if a different volume is required. The electronics of the reactor are contained within the heated reactor assembly.

Volumes ranging from 0.15ml to 3 ml are available. The reactor volume is labeled on the outside of the reactor assembly. (See also Page 4.7 for reactor replacement)

#### **PULSE DAMPENING CIRCUIT**

This consists of the Pulse Dampener (capacitor) in series with the Restrictor. See Section 1 for more information regarding the Pulse Dampening Circuit

The diaphragm-type pulse damper consists of a compressible fluid (isopropanol) held in an isolated cavity by an inert but flexible diaphragm. During the pumping phase of the pump cycle, the fluid pressure of the mobile phase displaces the diaphragm, compressing the fluid in the cavity and storing volume. During the pump refill phase the pressure on the diaphragm is reduced and the compressed fluid expands, releasing the volume it has stored. This helps to stabilize flow rate and pressure

To be effective, the pulse damper requires a back-pressure of approximately 500 psi or greater. To achieve this, a Restrictor is selected based on the viscosity/flow rate requirements of the method.

The restrictor is a tube packed with an inert material. It provides the back pressure needed for a smooth baseline.

On the control board for each reagent pump there is a replaceable coin cell battery. Use a CR2032, lithium battery, 3-volt, 20 mm diameter, 3.2 mm thick.

**WARNING:** Always release pressure from the pump slowly. A rapid pressure release could cause the pulse damper diaphragm to rupture.

## **Power**

The power connector is a standard IEC 320 type connector. Use the appropriate power cord for your local wall outlet and electrical code. The 120V version comes with a standard North American cord set. The 240V version comes with a cord set used in much of continental Europe or your local reseller may have provided the correct local cord set. If your local power outlets are different, you will need to obtain the appropriate grounded cord set.

---

The main power switch is located in the power connector assembly.

The fuse holder is located in the power connector assembly. For fuse replacement, see Section 4, Maintenance (page 4.8)

### Standard Configurations of Vector PCX

The Vector PCX is available as a dual pump system with a 0.5, 1.0 or 1.4 mL heated reactor volume, 120V or 240V operation, and is shipped completely assembled, calibrated, and tested.

The Vector consists of 2 reagent pumps, heated and ambient reactors, backflow and over-pressure safety devices, filters and flow conditioning components, reagent reservoirs, Air Barrier Tubing, and other accessories. Note that the two-reagent Vector PCX can easily be used for one-reagent applications.

If this system was purchased to analyze for carbamates, glyphosate, or in some cases amino acid analysis, there is an appropriate column kit, chemistry, and manual available for your application. All Pickering manuals can also be downloaded from [www.pickeringlabs.com](http://www.pickeringlabs.com).

#### SAFETY FEATURES IN THE VECTOR PCX

The Vector PCX system has features designed into the instrument and operation that will prevent reagent back-flow onto the column, and bursting of reactor tubing due to a blockage.

Post-column reagent can immediately damage the analytical column if the reagent flow is diverted in the wrong direction by a lack of HPLC flow. This is prevented by inserting a pressure switch before the column. The 500 psi switch prevents the accidental pumping of the reagents when there is no flow through the column, or in the event that the HPLC stops pumping, the reagent pumps will stop as well.

In the rare event there is a blockage in the post-column system, an integrated 500 psi over-pressure relief valve will open and divert the liquid into the beaker fed by the tubing at the outlet of the valve. This will prevent a bursting of tubing or fittings. By relieving the pressure, this will give you the opportunity to correct the blockage rather than having to replace the heated reactor.

## Section 3

# INSTALLATION AND OPERATION

---

- 3.1** Site Requirements
- 3.3** Instrument Unpacking and Preparation
- 3.3** Pump and Autosampler Connections
- 3.5** Priming of Eluants
- 3.5** Column and Guard Installation
- 3.5** Detector Connections
- 3.6** Gas Connections
- 3.6** Reagent pump Preparation
- 3.8** Basic Start-up
- 3.9** Over-pressure Relief Valve Connection
- 3.9** Chromatograms
- 3.9** Shutdown
- 3.1.1** Changing Reagents

Before the Vector PCX can be installed and qualified properly, the HPLC must be completely installed and in good working order (including pump, injector, detector and data collection system). Before installing the instrument, remove all organic compounds that are immiscible with the Pickering eluants as well as any hazardous chemicals.

Always wear safety glasses or goggles, laboratory coat, gloves, and other appropriate safety-clothing. Read and understand the instructions in the MSDS's of the chemicals to be used. Please contact Pickering Laboratories for our product MSDS and we can fax you a copy, or you can download them from our website at [www.pickeringlabs.com](http://www.pickeringlabs.com)

Note: The user is hereby notified that, if equipment is used in a manner not specified by the manufacturer, the protection provided by the equipment may be compromised.

## Site Requirements

### VECTOR PCX REQUIREMENTS

The Vector PCX weighs approximately 26 lbs. The minimum bench top space required for the Pickering system is approximately 17in (43 cm) high X 8.75in (21.6 cm) wide X 16in (41.2 cm) deep. This does not include the HPLC system. The total space requirement depends on the brand and model of the HPLC.

---

For most cases, it is best to place the LC pump and injector system on the left side of the Vector PCX, and the detector on the right.

In addition to the power outlets required for the HPLC system, one grounded outlet will be needed.

Nitrogen, helium, or argon (in order of preference), is required to pressurize the reagent reservoirs. The Vector PCX requires gas pressure of 75 psi (5 bar) at the gas inlet. An adaptor from the gas regulator to 1/8 inch OD tubing is required. To minimize oxidation of the OPA reagent, use oxygen-impermeable tubing for the entire gas supply line (Air Barrier Tubing or metal).

A waste container should be provided for the waste line from the HPLC detector.

#### **HPLC REQUIREMENTS**

Since every HPLC is different, the following procedure has been generalized. Before attempting to connect any tubing, examine the HPLC setup, and determine the best possible means of making the connections. Small ID tubing (0.010") should be used wherever the sample is in the flow path. PEEK ferrules must be used to make the connections on the mixing manifolds of the Vector PCX (i.e. the column outlet connection).

Ensure that the HPLC pump, injector and detector meet all of the necessary requirements for the application to be run.

For all applications, the pressure rating of the detector flow cell must be  $\geq 110$  psi (7.5 bar)

#### **GLYPHOSATE ANALYSIS**

Pump

Minimum binary gradient elution

Piston wash capability is preferable

Injector

Tefzel or PEEK rotor seal for injector valve

Tefzel or PEEK needle seat if it is an autosampler

For water samples, at least 200 $\mu$ l injection; preferably 400 $\mu$ l capability

#### **CARBAMATE ANALYSIS**

Pump

Minimum binary gradient elution

Injector

For water samples, at least 200 $\mu$ l injection; preferably 400 $\mu$ l capability

For all other applications, review the method notes for chemistry requirements.

## Instrument Unpacking and Preparation

### UNPACKING

Unpack all cartons and review the contents using the Packing List to ensure that all of the items are present. If any items are missing, immediately contact Pickering Laboratories, Inc.

Toll Free: (800) 654-3330

International: (650) 694-6700

Unpack the instrument and place it on the bench. Place it so there is enough clearance between the PCX and the HPLC, detector, and the edge of the bench.

### PREPARATION AND INSPECTION

Remove the cover. Check for any damage to the internal parts. Make sure that the pump is secured to the chassis. Replace cover.

Connect the power cord to the outlet in the back of the Vector PCX, just above the power switch.

Turn on the power, but do not operate the buttons. Check that the power indicator light turns green.

## Pump and Autosampler Connections

NOTE: Do not fit the analytical column and guard yet.

Wash the HPLC reservoirs if it is a new HPLC system, or if the eluants are more than 2 weeks old. Wash the reservoirs with laboratory detergent and hot water. Rinse with deionized water. Wipe down the dip tubes on the caps with methanol and a clean, lint-free cellulose tissue. Avoid touching the tubing or the interior of the reservoir with your skin and do not leave caps and lines dangling without a reservoir because this can cause contamination.

NOTE: Wash the reagent reservoirs as well and set them aside temporarily.

Fill reservoirs with 80/20 Water/Methanol

Open the prime-purge valve on the HPLC. Purge each line in the system with a water/methanol mixture to flush the system. Set the flow rate to the maximum and purge at least 25 mL through each line.

Drop the flow rate to 1 mL/min and close the prime-purge valve to flush the lines to the injector.

**CONNECTING THE PRESSURE SWITCH**

Use the HPLC connection kit provided with the system. Use the appropriate fittings for the HPLC. The inlet and outlet of the pressure switch should be a Parker-style fitting.

Use one of the two methods below for making the connections.

Connect the outlet of the pump to the inlet of the pressure switch. The inlet is the bottom opening. Next connect a tubing from the outlet of the pressure switch to the autosampler. The outlet is the top opening on the pressure switch.

OR

Connect a tee to the inlet of the pulse dampener on the HPLC. Connect a line from the outlet of the pulse dampener to the inlet of the pressure switch and place a high-pressure plug in the outlet of the pressure switch on the Vector PCX. Connect the inlet and outlet of the pump through the tee. Refer to the diagram below for more information.

Connect one end of the column inlet tubing to the injector. Use the appropriate fittings. Leave the other end of the tubing free to protect the column in the next step.

Flush the line from injector into a beaker.

With the HPLC pump running, carefully crack the outlet of the pressure switch to remove any air bubbles. Tighten the fitting again once all air is removed.

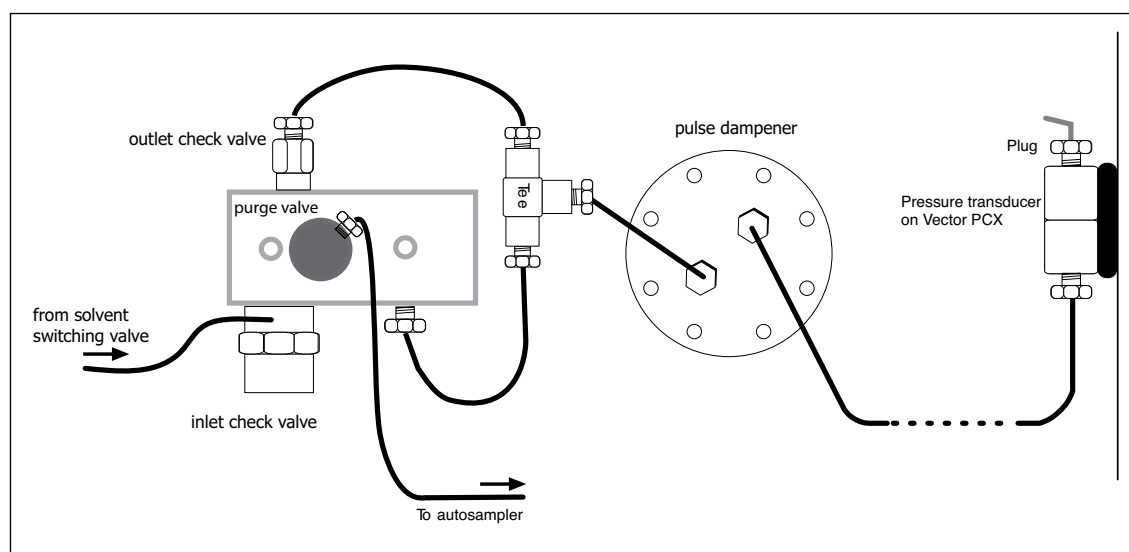

---

## Priming of Eluants

Before proceeding, check for and repair any leaks between the pump and the outlet of the autosampler. Once you are certain there are no leaks, do not open the connections between the pump and injector.

Important! If any application other than carbamates is to be used, remove water/methanol and replace with water. Flush at least 25 mL through lines and flush injector line.

Fill the reservoirs with the appropriate eluants/mobile phases and again flush at least 25 mL OF EACH ELUANT with the purge valve in the open position.

Close the purge valve, and pump each eluant at 1 mL/min for 5 minutes.

If buffers will be used as the eluant, use pH paper to measure the pH of the solution coming through the tubing to verify that priming is complete.

## Column and Guard Installation

Set the HPLC to 100% of the storage solution in the column

Set the flow rate to 0.2 mL/min

When you are certain that the liquid coming out is appropriate for your application (see above) connect the guard column.

Connect one end of the 0.010" peek inlet tubing provided to the guard column/cartridge. Swage the nut and ferrule on the other end, but do not connect to the column. Turn on the flow at the recommended rate for the column. Wait for liquid to drip from the outlet of the tubing. Connect the inlet of the column, and then connect the outlet of the column to the inlet of the Mixing Manifold 1.

NOTE: The inlet is the top 10/32 opening on Mixing Manifold 1. The Vector PCX is shipped with a plug in this position. Remove the plug in order to connect the column outlet tubing. Be sure to use a PEEK Lite-touch fitting at this port.

Monitor the pressures.

## Detector Connections

Connect a 1/16 inch x 0.020 inch ID tubing from the outlet of the flow cell to the external 100psi backpressure regulator using a 1/4-28 nut with a 1/16 inch reversed-ferrule (PN 3101-0007 and 3101-0008). There is an arrow on the back pressure regulator indicating direction of flow. Insure that the arrow is pointing away from the detector and toward the waste line.

Connect the 0.020 inch ID PTFE tubing provided (PN 2101-0225) to the outlet of the external 100 psi back-pressure regulator. Place the other end in an appropriately labeled waste container.

Using the ZDV (zero dead-volume) union provided in the packing kit, connect a 0.010" ID tubing from the outlet of the reactor to the inlet of the detector flow cell. The outlet of the ambient reactor is the length of tubing hanging at the right side of the Vector PCX. See also, Section 2 Overview for identification of parts. Use the PEEK Lite-touch fittings in the connection kit.

Set the time constant on the detector to 2–4 seconds.

### Gas Connections

Set the regulator on the inert gas supply to between 50-75 psi. Using a portion of the Air Barrier tubing (PN 2103-0463) and the 1/4-28 Nut and 1/8 ferrule (PN 3101-0005 and 3101-0006) connect the "Gas In" port to the inert gas supply. Turn on the main gas supply. Switch the toggle valve to the ON position to start gas flow. Let the gas system purge for about one minute. Switch the toggle valve off.

Each tubing line from bottle to gas manifold has its own check valve to prevent back flow of gas from the pressurized reagent reservoirs.

Connect long end of the Air Barrier tubing with a check valve to the manifold, and the short end to the inlet at the TOP of the reservoir cap. Use the 1/4-28 Nut and ferrule (PN 3101-0005 and 3101-0006). The arrow on the check valve should point toward the reservoir cap.

See also diagram in Section 2 Overview for proper location.

### Reagent Pump Preparation

Wash the reagent reservoir(s) with laboratory detergent and hot water. Rinse with deionized water. Wipe down the dip tubes on the caps with methanol and a clean, lint-free cellulose tissue. Avoid touching the tubing or the interior of the reservoir with your skin and do not leave caps and lines dangling without a reservoir because this can cause contamination.

Fill the reservoirs with about 100mL of deionized water.

If a chemical kit was ordered with the system, appropriate labels are included. Place them on the reservoirs. If no chemical kit was ordered, the reservoirs should be labeled with an appropriate label using the GLP of the laboratory.

Connect the reagent lines from the front of the Vector PCX to the reservoir caps using the Air Barrier tubing provided. The reagent tubing should be connected to the reagent bottle cap directly facing the blue shut-off valve. Connect the reagent bottles to the pump using the Air Barrier tubing. Nuts and ferrules (1/4-28) are provided.

Feed both lines of the 1/4" OD C-flex tubing to a bottle of 80/20 Water/Methanol.

**PRIMING THE PUMP AND FLUSH LINES**

To prime the piston wash lines for the self-flush head, simply place the inlet line in the flush solution and connect a syringe to the outlet line. Apply suction until the line is filled with flush solution. Place the outlet line in the flush solution. Secure both flush lines in the flush solution container so they stay immersed during the pump operation.



The 3-digit display shows the pump flow rate (mL/min), system pressure (psi), or the set upper or lower pressure limit (psi) when operating. The choice of display is selected with the MODE key.

Press the MODE key to show mL/min. Use the up/down arrow keys to set the flow rate to 0.3ml/min. Press the Run/Stop key once to start the pump.

Attach the 20 mL syringe to the Luer fitting in the center of the prime/purge valve. Open the valve by turning it counter-clockwise about one turn. Apply suction with the syringe to draw reagent through the pump. Use strong suction to remove bubbles from the reagent pump, reagent supply line and pulse dampener. Close the valve by turning it clockwise; only gentle pressure is needed to close the valve. Keep the Luer fitting clean by rinsing it with water after use.

Press "MODE" once to display the pressure on each pump. It should read about 500-800 psi. If the pressure does not rise, try priming the pump again.

Monitor the pressure for about 10 minutes to verify stability, and then stop the Vector PCX and the HPLC.

Replace the water in the reagent bottles with reagents.

Prime the pump.

## Basic Start-up

This section describes the basic start up of the Vector PCX (enable button, reagent pump, heated reactor)

For chromatographic conditions, please refer to the appropriate Application Section or column sheet included with every Pickering column.

Always ensure that liquid is flowing through the system from the HPLC pump and that there is  $\geq 500$ psi pressure on the column (indicating liquid flowing) before starting the reagent pump.

Start the HPLC pump at the desired flow rate for your application. Allow the pressure to build.

Set the column temperature to application specifications on the HPLC.

With the HPLC pump running and the column pressure at  $\geq 500$ psi the enable button glows orange. Press this button once, this will cause the reactor and pump displays to light up and the heated reactor to begin to warm to its current set point.

Adjust the reactor set point by holding down on the blue “set” key while using the up/down arrows to select the desired number. When you have reached the set point, let go of the buttons and the heater will begin to warm up to the desired temperature.

Ensure that the reagent pumps are at the desired flow rate (Pickering recommends 0.3 mL/min). Use the “Mode” key to select the display function on the pump (described in further detail below).

When the reactor is at temperature, turn on the post-column pumps.

With the display showing mL/min, use the up/down arrow keys to adjust the flow rate if needed. Turn on the reagent pump by pressing the Run/Stop key.

Press “Mode” once to display the pressure in psi. Watch to ensure that the pressure is stable and reads about  $800 \pm 50$ psi. If there is no pressure on the pumps, they need to be primed (see above).

Note: It is strongly recommended that you warm the reactor prior to starting the reagent pumps to prevent over-pressure of the reactor. If the relief valve opens, a partial or complete blockage is indicated.

---

## Over Pressure Relief Valve Connection

Using the short PTFE tubing provided (PN 1100-2731), connect the over-pressure relief valve – feed into a clean, dry beaker.

## Chromatograms

Look in the column box for the gradient program and conditions.

Load the appropriate temperatures and gradient method for the application and verify the set-points.

Start the HPLC, press Enable when the column pressure reaches  $\geq 500$  psi (35 bar). When the reactor reaches temperature, turn on the post-column pump.

Set the HPLC pump to run the starting eluant conditions, and while the system is equilibrating, set up the method.

When the method is set up and the systems pressures are acceptable, make an injection of the appropriate test mix. Collect at least 3 chromatograms.

For Carbamate and Glyphosate Analyses:

Set the detector excitation wavelength to 330 nm and the emission wavelength to 465 nm

Do at least two runs of the appropriate test mixture. Inject 10 $\mu$ L.

Compare the chromatogram with that of the QC test of the system and column.

Verify that the system is functioning by using the IQ/OQ document as reference (See Appendix)

## Shutdown

Turn off the Vector by lowering the flow rate of the HPLC pump so that the column pressure drops below 500psi (thereby disabeling the reactor and reagent pumps). This can be done manually by setting the HPLC at a low flow rate, or via the Slowdown method below.

Choose an eluant that elutes contaminants from the column. For example, use methanol for a reversed-phase column and regenerant for an ion-exchange column.

After Vector pumps have stopped, set the HPLC pump at the normal flow rate to flush the system for at least 20 minutes.

Set the HPLC pump to  $\leq 0.1$  mL/min.

Turn off the detector lamp.

The **slowdown method** can be used to accomplish all the above steps.

Step	Time (min)	% Eluant	Flow (mL/min)
0	0	100	0.02
1	5	100	0.02
2	7	100	Normal flow*
3	27	100	Normal flow*
4	27.1	100	0.02

(\*) Normal flow rates are different for various columns. Follow the instructions that came with your column.

Note: It is VERY important to allow the heated reactor to flush out and cool before stopping the HPLC pump. If the heated reactor is not cooled and flushed properly, it is very likely that a blockage will form in the heated reactor.

THE INERT GAS SHOULD BE LEFT ON TO PRESERVE THE OPA REAGENT. CLOSE THE BLUE REAGENT VALVE ON THE RESERVOIR TO PREVENT SIPHONING OF THE REAGENT WHEN NOT IN USE.

#### LONG TERM SHUTDOWN

Remove the column and guard, and the post-column reagents. Put water/methanol (80/20) on both the HPLC pump and the reagent pump. Pump water/methanol through the entire system for 30 minutes.

### Changing Reagents

When changing reagent, first vent the reagent bottle by pushing down the valve, then turn off the gas using the toggle valve on the manifold. Now you can safely remove the cap. It is convenient to have extra bottles so that you can simply transfer the cap without setting it down and risking contamination.

*Section 4***VECTOR MAINTENANCE**

---

- 4.1** Pump Maintenance
- 4.1** Replacing Piston Seals
- 4.4** Cleaning Pump Head Assembly
- 4.5** Cleaning/Replacement of Check Valves
- 4.6** Replacing Pistons
- 4.7** Replacement of Reagent Filter
- 4.7** Replacement of the Heated Reactor
- 4.8** Fuse and Battery Replacement
- 4.9** Maintenance Schedule



Caution: To avoid electrical shock and possible injury, remove the power cord from the back panel of this equipment before performing any type of service procedures. The equipment must be isolated or disconnected from the hazardous live voltage before access by the operator.

To avoid chemical or electrical hazards, always observe safe laboratory practices while operating this equipment

Always wear safety glasses or goggles, laboratory coat, gloves, and other appropriate safety-clothing. Read and understand the instructions in the MSDS's shipped with the chemicals. If the MSDS's are missing, please contact Pickering Laboratories and we can fax you a copy, or you can download them from our website at [www.pickeringlabs.com](http://www.pickeringlabs.com).

### **Pump Maintenance**

Lower than normal pressure, pressure variations, or leaks in the pumping system can all indicate possible problems with the piston seal, piston, or check valves. Piston seal replacement could be necessary after 1000 hours of running time.

#### **REPLACING THE PISTON SEALS**

See also Figure 4-1 for the following procedure.

Turn OFF the power to the Vector PCX.

Close the blue reagent valve on the Reagent reservoirs to prevent the reagent from flowing out the tubes during this procedure.

Disconnect the Air Barrier tubing from the reagent bottle cap and place in a solution of 80% water/MeOH.

Prime the pump to flush most of the reagent out of the pump head and replace it with MeOH solution. This makes the following procedure easier and extends the life of the pump.

Remove the outlet line from the outlet check valve.

Using a 5/32" Hex wrench, loosen the two nuts at the front of the pump head.

**CAUTION:** Be careful not to break the piston when removing the pump head. Twisting the pump head can cause the piston to break.

Carefully separate the pump head from the pump. Move the pump head straight out from the pump and remove it from the piston. Be careful not to break or damage the piston. Also remove the seal and seal backup washer from the piston if they did not stay in the pump head. Remove the O-ring.

Carefully separate the flush housing from the pump. Move the flush housing straight out from the pump and remove it from the piston. Be careful not to break or damage the piston. Also remove the self-flush diaphragm from the piston by carefully grasping the sealing flange on two sides and sliding it straight out on the piston being careful not to exert side pressure that may break the piston.

Each replacement seal kit contains one seal, one backup washer, a seal insertion/removal tool, a diaphragm and a pad to clean the piston when changing the seal.

Insert the flanged end of the seal insertion/removal tool into the seal cavity on the pump head.

Tilt it slightly so that the flange is under the seal and pull out the seal.

**CAUTION:** Using any other "tool" will scratch the finish.

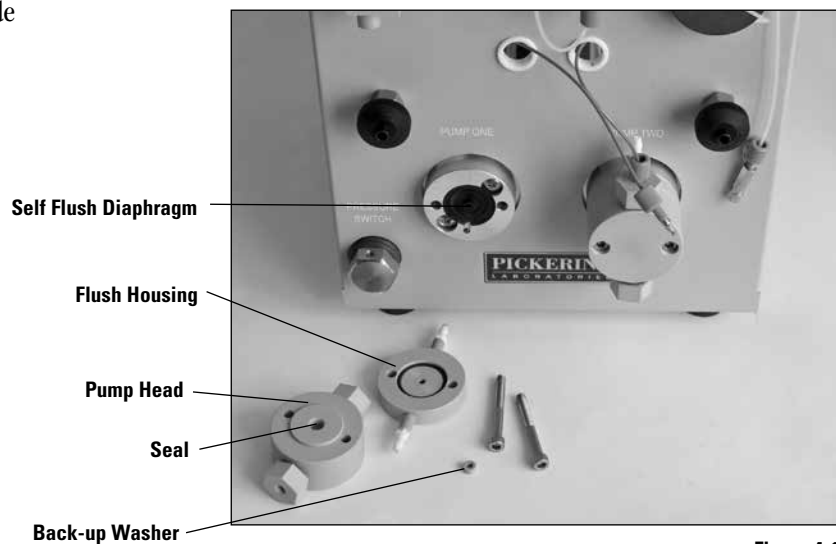

Figure 4-1

Clean the Piston to remove any salt build up or dirt. If there is a lot of build-up, clean the piston using the scouring pad as described below. Otherwise, use a lint-free cloth dampened with alcohol to wipe the piston clean.

It is not necessary to remove the piston from the housing to clean the piston.

To Clean the Piston using the Scouring pad:

Use the scouring pad included in the seal replacement kit. Gently squeeze the piston within a folded section of the pad and rub the pad along the length of the piston. Rotate the pad frequently to assure the entire surface is scrubbed. Do not exert pressure perpendicular to the length of the piston, as this may cause the piston to break. After scouring, use a lint-free cloth, dampened with alcohol, to wipe the piston clean.

Before replacing the pump head and seals, inspect, and if necessary, clean the pump head and check valves as described below.

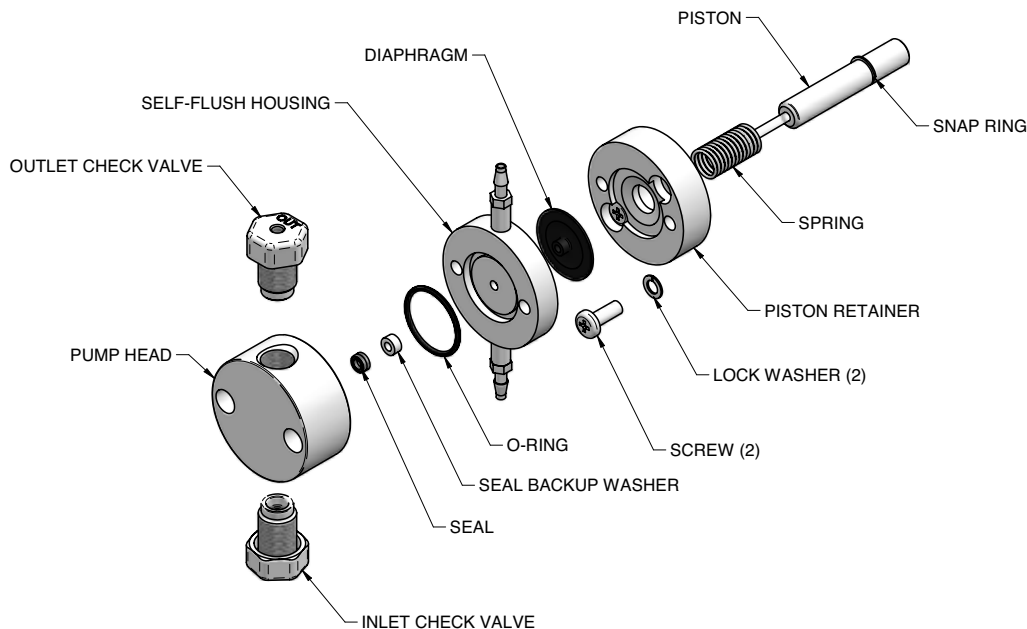

**Pump Head Assembly**

**Figure 4-2**

Place a high pressure replacement seal on the rod-shaped end of the seal insertion/removal tool so that the spring is visible when the seal is fully seated on the tool. Insert the tool into the pump head so that the open side of the seal enters first, facing the high pressure cavity of the pump head. Be careful to line up the seal with the cavity while inserting. Then withdraw the tool, leaving the seal in the pump head. When you look into the pump head cavity, only the polymer portion of the seal should be visible.

---

Gently place the diaphragm onto the piston with the center hub protruding towards you. Push the diaphragm all the way back into recess and against metal base of piston. Do not exert pressure perpendicular to the length of the piston, as this may cause the piston to break.

Carefully align the flush housing and gently slide it into place on the pump. Make sure that the Inlet valve is on the bottom and the Outlet valve is on the top.

Line up the pump head and carefully slide it into place. Be sure that the Inlet valve is on the bottom and the Outlet valve is on the top. Do not force the pump head into place.

Tighten both hex screws in the pump head using the 5/32" wrench. DO NOT over tighten! Turn each screw alternately 1/4 turn while gently wiggling the pump head to center it.

Reattach the inlet and outlet lines. Change the flushing solution.

Lastly, condition the new seal using the following procedure:

Using a restrictor coil or a suitable column, run the pump with a 50:50 solution of isopropanol (or methanol) and water for 30 minutes at a back pressure of 2000 psi.

Note: Use only organic solvents to break-in new seals. Buffer solutions and salt solutions should never be used to break-in new seals.

#### **CLEANING THE PUMP HEAD ASSEMBLY**

Note: If you choose to remove the piston seal or self-flush diaphragm, you should have a new set on hand to install after cleaning. It is not recommended that you reinstall the used piston seal or diaphragm since they are likely to be scratched and damaged during removal and would not provide a reliable seal if reused. If you decide to remove the seal, use only the flanged end of the plastic seal removal tool supplied with the seal replacement kit, and avoid scratching the sealing surface in the pump head.

Inspect the piston seal cavity in the polymer pump head. Remove any foreign material using a cotton swab or equivalent, and avoid scratching the sealing surfaces. Be sure no fibers from the cleaning swab remain in the components.

The pump head, check valves, and flushing housing may be further cleaned using a laboratory grade detergent solution in an ultrasonic bath for at least 30 minutes, followed by rinsing for at least 10 minutes in distilled water. Be sure that all particles loosened by the above procedures have been removed from the components before reassembly.

**CAUTION:** When cleaning check valves, be sure that the ball is not against the seat in the ultrasonic bath. This may destroy the precision matched sealing surface and the valve will not check.

If the check valves have been removed, tighten each check valve to 12.5 inch-pounds. This is usually done by tightening each check valve by hand, then using a torque wrench. If there is a leak, tighten to 13-14 inch-pounds, but NEVER above 15 inch-pounds.

If no torque wrench is available, tighten each check valve no more than 1/8 turn past finger tight. DO NOT over tighten the check valve assembly as this will deform the seal and it will not work properly.

#### CLEANING/REPLACEMENT OF CHECK VALVES

Each check valve assembly contains two capsules. The sapphire seat in each capsule must be oriented downward in all cases in the final pump assembly.

Note: The inlet check valve has a larger opening (1/4"-28, flat-bottom seat) for the 1/8" inlet tubing; the outlet check valve has a smaller opening (#10-32, cone seat) for the 1/16" outlet tubing.

The inlet check valve must be connected at the larger opening in the pump head.

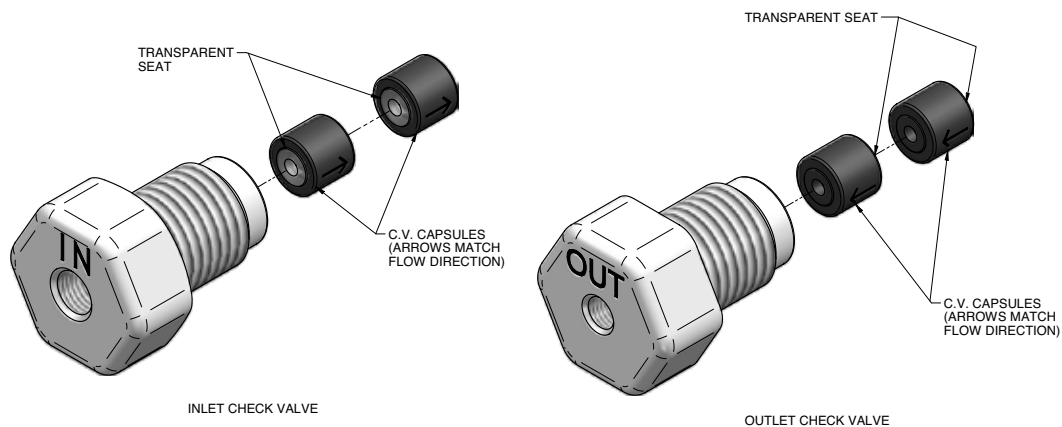

#### Check Valves

Figure 4-3

Many check valve problems are the result of small particles interfering with the operation of the check valve. As a result, most problems can be solved by pumping a strong solution of liquid laboratory grade detergent through the check valves at a rate of 1 ml/min for one hour. After washing with detergent, pump distilled water through the pump for fifteen minutes. **Always direct the output directly to a waste beaker during cleaning. If this does not work, the check valve should be replaced.**

---

If the check valves have been removed, tighten each check valve to 12.5 inch-pounds. This is usually done by tightening each check valve by hand, then using a torque wrench. If there is a leak, tighten to 13-14 inch-pounds, but NEVER above 15 inch-pounds.

If no torque wrench is available, tighten each check valve no more than 1/8 turn past finger tight. DO NOT over tighten the check valve assembly as this will deform the seal and it will not work properly.

Note: The inlet check valve has a larger opening (1/4"-28, flat-bottom seat) for the 1/8" inlet tubing; the outlet check valve has a smaller opening (#10-32, cone seat) for the 1/16" outlet tubing.

#### **REPLACING THE PISTON**

Turn off the power to the Vector PCX and then remove the power cord.

Remove the cover from the Vector PCX by removing the 6 screws on each side of the instrument.

Remove the pump head as described above.

With your thumb pressing the piston retainer against the pump housing, remove the two phillips head screws from the retainer. Do not allow the spring pressure to force the retainer away from the housing as the screws are loosened.

After both screws have been removed, slowly allow the spring pressure to push the retainer out of the housing. Gently pull the retainer straight out and carefully remove it from the piston and threaded rods. Also, gently pull the spring straight out of the housing and remove.

Grasp the metal base of the piston assembly so that you avoid exerting any pressure perpendicular to the length of the piston, and gently pull it from the pump housing.

Use a small screwdriver to remove the snap ring from the groove on the old piston and place it into the groove on the new piston.

Place a small amount of high quality lightning grease on the back end of the metal base of the piston assembly. Grasp the metal base of the piston assembly near the front so that you avoid exerting any pressure perpendicular to the length of the piston, and gently slide it into the pump housing.

Gently slide the spring over the piston assembly and back into the pump housing. Carefully align the retainer and gently push it straight in against the spring force until the retainer is against the housing. If misalignment with the piston occurs, wiggle while pushing the retainer to align the piston & retainer.

Hold the retainer flush against the housing with your thumb. Insert and tighten the phillips head screws. Do not allow the spring pressure to force the retainer away from the housing. Insure that there are no gaps between the retainer and the housing.

Re-attach the pump head as described above.

### Replacement of Reagent Filter

The reagent filters are located in each of the mixing manifolds and in front of the flow restrictors. When there is an increase in the reagent pressure, it is usually an indication that the reagent filter should be replaced.

The reagent filters are 10 or 0.5 $\mu$ m frits inside a PEEK housing. 10 $\mu$ m in the mixing manifolds and 0.5 $\mu$ m in front of the flow restrictors. They are disposable and cannot be cleaned.

To replace the filter, ensure that both HPLC and Reagent pumps are stopped. Turn the Blue valve on the reagent bottles to the Closed position.

Disconnect the Lite-touch fitting from the inlet of the filter that is blocked.

Using a 7/16" wrench, loosen and remove the blocked reagent filter. Replace it with a clean filter (PN 3102-9040 - 10 $\mu$ m. PN 3102-9042 - 0.5 $\mu$ m). Tighten firmly.

Re-connect the reagent line(s).

Turn on the HPLC pump, press the Enable button, and then start the Reagent pump to check for leaks.

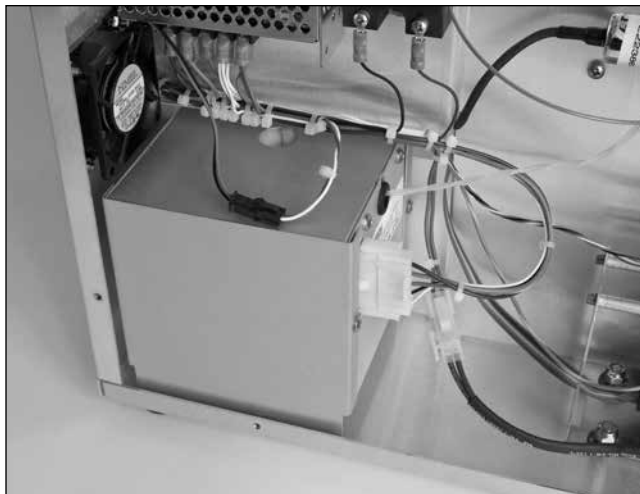

### Replacement of the Heated Reactor

Unless there is a complete blockage in the heated reactor, it can usually be cleaned. For cleaning procedures, refer to the troubleshooting section of this chapter.

If the reactor is completely blocked, it must be replaced.

To replace the reactor, turn off the power to the Vector PCX.

Unplug the power cord and remove the cover by loosening the 6 screws on each side.

---

The heated reactor is located at the lower left back corner. Remove the three Phillips head screws that hold it to the chassis. (Access to these screws is from the right side)

Unplug the white cable harness by squeezing on the two tabs and then pulling out.

A replacement reactor (PN 1452-0162 for 120V 0.5mL or 1452-0163 for 240V 0.5mL) can be installed by reversing the above steps.

### Fuse and Battery Replacement

The fuse holder is located in the power connector assembly. To change the fuse, first remove the power cord from the connector. Carefully pry out the fuse clip with a small screwdriver. Replace with the specified-type fuse as listed under Specifications.

**Warning.** Ensure that the power cord is disconnected before replacing a fuse. Use only the specified-type fuse.

**Attention.** Assurez vous que le cable secteur n'est pas connecté avant de changer un fusible.

**Warnung.** Sicherungen dürfen nur bei nicht angeschlossenem Netzkabel ersetzt oder gewechselt werden.

**Cuidado.** Asegúrese que el cable de red está desconectado antes de instalar o cambiar un fusible.

**Attenzione.** Assicuratevi che il cavo di alimentazione sia scollegato prima di installare o sostituire un fusibile.

**Waarschuwing.** Zorg dat de voedingskabel losgekoppeld is, voordat een zekering wordt geplaatst of vervangen.

**Avvertimento.** Fare attenzione che la corda del voltaggio sia staccata prima di cambiare valvole. Usa solo valvole di capacità precisata dalla fattoria.



#### **REAGENT PUMP BATTERY REPLACEMENT**

There is very little drain on this battery during normal operation.

The battery provides power for the memory that holds the current pump configuration. If the pump is set at a flowrate other than 1.00 or 10.0 and the power is turned off, when the power is turned back on the flowrate should appear as it was set. If this flowrate does not appear the battery will need to be replaced.

On the control board for each reagent pump there is a replaceable coin cell battery.

Use a CR2032, lithium battery, 3-volt, 20 mm diameter, 3.2 mm thick.

---

Unplug the unit.

Remove the cover.

The battery can be seen in the lower right corner of the circuit board. The battery is circular and has a positive pole mark (+) on the top. Gently pull it from its socket.

With the positive mark (+) up, gently slide the new battery into the battery socket. Be sure the battery is all the way into place. It must contact the base of the battery socket.

Replace the cover to the unit.

Plug the unit back in.

**WARNING:** Unplug power cord before removing cabinet lid.

## Maintenance Schedule

Check for leaks around all fittings and record column and reagent pressures daily.

Replace the 10 $\mu$ m reagent filter on the mixing manifold every 3 months.

Replace the 0.5 $\mu$ m filter which protects the flow restrictor every 3 months or if reagent pump pressure increases over 1000 psi.

Change pump seals every 12 months.

Replace the heated reactor every 2 years.



## Section 5

# TROUBLESHOOTING

---

- 5.1** Contact Pickering Laboratories for Support
- 5.2** Instrument Parameter Log
- 5.2** Troubleshooting Advice
- 5.3** Common System Problems
- 5.4** Common Chromatography Problems
- 5.5** Common Column Problems
- 5.6** Application-specific Troubleshooting
  - Carbamate
  - Glyphosate
- 5.6** Reagent Pump Troubleshooting
- 5.7** Procedures
  - To Remove Silica deposits From the Reactor
  - To Remove Mineral Deposits In The Reactor From Hard Water
  - To Remove Grease Deposits
  - If Reagent Backflows Onto Column
  - If TRIONE Backflows Onto Column
  - If NaOH Is On Column
  - To Remove Iron Contamination From Column
  - To Pump RESTORE Through The Glyphosate Column
  - Vacuum Priming



**CAUTION:** To avoid electrical shock and possible injury, remove the power cord from the back panel of this equipment before performing any type of service procedures.

### Contact Pickering Laboratories for Support

There are several easy ways to contact Pickering Laboratories for Technical Support:

Email: [support@pickeringlabs.com](mailto:support@pickeringlabs.com)

Telephone: 800-654-3330 or 650-694-6700

Fax: 650-968-0749

Web Site: [www.pickeringlabs.com](http://www.pickeringlabs.com)

Click on the Support tab to send us an email.

---

We will ask you a set of standard questions:

What application are you running?

What are the pressures in your Vector PCX system?

What is the brand and model of your HPLC system?

What type of samples are you injecting?

Please email or fax to us a chromatogram

### Instrument Parameter Log

If you should have any problems with your Vector PCX, the Instrument Parameter Log is a key part to find the cause of, and solving any problems. It is a good idea to keep a record of the daily instrument parameters.

A daily parameter log will enable you to see any trends in pressure, and to notice something out of the ordinary before it becomes a serious problem.

Pickering Laboratories strongly recommends that you record your daily operating pressures, and any maintenance performed on the instrument. This log will be invaluable to your laboratory for troubleshooting and problem prevention.

### General Troubleshooting Advice

Rules of Dolan and Snyder [see references]

- Rule of One: Make one change at a time.
- Rule of Two: Confirm the problem before fixing it.
- Substitution Rule: Swap in a good part for a questionable one.
- Put it Back: If swapping does not fix it, put the original back in.
- Write it Down: Changes or modifications, incidents.
- Crystal Ball: Preventive maintenance saves more time in the long run.
- Buffer Rule: Remove buffers from LC when not in use.

General Procedure for Troubleshooting

- Examine the system front to back. Repair all leaks.
- Verify that all settings, eluants, reagents, valves, etc. are according to specifications.
- Have there been any changes in the system?
- Compare against reference conditions: standard sample, column, parameter log as appropriate.

- Gather information: observations, manuals, books, technical assistance.
- Test your conclusions about the nature of the problem.
- Start working.

Before making any change in the gradient, temperature, or other operating conditions, get at least two chromatograms in a row with the same problem. After you make a change, get at least two chromatograms showing the same effect of the change. This is especially true when you are trying to optimize gradient conditions.

OBSERVED PROBLEM	COMMON CAUSE	ACTION TO TAKE	NOTES
Low Reagent pressure	<ol style="list-style-type: none"> <li>1. Air in reagent pump</li> <li>2. Reagent flow rate too low</li> <li>3. Leaking fittings</li> </ol>	<ol style="list-style-type: none"> <li>1. Check for bubbles</li> <li>2. Check for leaks</li> <li>3. Pressure-test the pump to check for seal integrity</li> </ol>	Tighten leaking fittings
High Reagent pressure	<ol style="list-style-type: none"> <li>1. Obstruction of flow path by deposits</li> <li>2. Over-tightened fittings</li> <li>3. Pinched tubing</li> <li>4. Obstruction of detector flow-cell</li> <li>5. Faulty back-pressure regulator</li> </ol>	Determine the exact location of the blockage. Disconnect one fitting at a time, moving backward from the back-pressure regulator end, until the pressure drops	A: For partial blockage, clean tubing with solvent/water B: For total blockage, replace appropriate part
Reagent pump stops or delivers wrong flow rate		<ol style="list-style-type: none"> <li>1. Check pump setting</li> <li>2. Check reagent pressurization</li> <li>3. Check pump seal for leakage</li> <li>4. Clean check valves</li> </ol>	
Over-pressure relief valve is opened	There is a blockage in the system	Determine the exact location of the blockage. Disconnect one fitting at a time, moving backward from the back-pressure regulator end, until the pressure drops	Flush the system with solvent/water until pressure drops, or replace appropriate part
Blocked Heated Reactor	<ol style="list-style-type: none"> <li>1. Improper Shutdown</li> <li>2. Deposits in the reactor</li> <li>3. Contaminated reagents</li> <li>4. Use of CaOCl vs NaOCl</li> </ol>	Follow the procedure for removing mineral or silica deposits	

## Common System Problems

OBSERVED PROBLEM	COMMON CAUSE	ACTION TO TAKE	NOTES
High Background Signal	<ol style="list-style-type: none"> <li>1. Contaminated Eluant</li> <li>2. Bacterial Growth</li> <li>3. Fingerprints</li> <li>4. Contaminated Reagent(s)</li> <li>5. Defective chemicals</li> </ol>	Wash all reservoirs and flush lines	The post column reactions are very sensitive to even minute contaminations
Noisy Baseline	<ol style="list-style-type: none"> <li>1. Worn pump seal</li> <li>2. Faulty check valves</li> <li>3. Detector noise</li> <li>4. Chemical contamination</li> <li>5. Reagent too old</li> </ol>	<ol style="list-style-type: none"> <li>1. Check for pattern in the noise.</li> <li>2. If the background signal is also elevated, check for chemical contamination, or an error in formulation</li> </ol>	<p>Match the frequency of the noise to one of the pumps.</p> <p>If the noise is random, check the detector</p>
Peaks disappear or diminish	<ol style="list-style-type: none"> <li>1. OPA reagent expired</li> <li>2. Improper Reagent preparation</li> <li>3. Out of Hydrolysis Reagent</li> <li>4. Reactor at wrong temperature</li> <li>5. Reagent flow rate improper</li> <li>6. Dirty flow cell</li> <li>7. Dirty auto sampler</li> <li>8. Deteriorated samples</li> <li>9. Metal contamination of column</li> <li>10. Oxidized TRIONE or OPA</li> <li>11. Reagent pump mis-adjusted</li> </ol>	<ol style="list-style-type: none"> <li>1. Prepare fresh reagent</li> <li>2. Prepare fresh standards from neat reference material.</li> <li>3. Test with a second fluorescent detector.</li> <li>4. Change the rotor seal of the auto sampler or use a manual injector.</li> <li>5. Check reactor temperature</li> <li>6. Check for oxidized reagent</li> <li>7. Clean the flow cell</li> <li>8. Follow the procedure for Iron removal</li> <li>9. Remove all stainless steel frits from reservoirs</li> <li>10. Clean or replace any corroded parts.</li> </ol>	<p>A: All disappear except 1-naphthol and carbaryl = OPA reagent expired</p> <p>B: All disappear except 1-naphthol = Out of Hydrolysis Reagent</p> <p>C: Varied peak size, some missing = Reactor at wrong temperature</p> <p>D: All peaks diminish = dirty flow cell, auto sampler, or deteriorated samples</p> <p>E: Iron contamination can be caused from samples, long column storage, stainless steel frits in the eluant reservoirs, corrosion in system</p>
Retention times not stable, especially in early part of chromatogram	<ol style="list-style-type: none"> <li>1. Equilibration time too short</li> <li>2. Too much internal volume</li> <li>3. Leaking proportioning valve</li> <li>4. Auto sampler problems</li> </ol>	<ol style="list-style-type: none"> <li>1. Increase equilibration time by 2 minute increments</li> <li>2. Re-plumb system with ZDV* connections or 0.010" ID tubing</li> </ol>	
Artifacts in Baseline	<ol style="list-style-type: none"> <li>1. Contamination in Eluant reservoir</li> <li>2. Corrosion of spargers/filters</li> <li>3. Volatile amines used and worn in laboratory</li> </ol>	<ol style="list-style-type: none"> <li>1. Replace eluants</li> <li>2. Clean reservoir with soap and water</li> <li>3. Remove spargers/ or eluant filters</li> </ol>	
Retention Times drift over a long time	<ol style="list-style-type: none"> <li>1. Buildup of contaminants</li> <li>2. Room temperature changes greatly with the seasons</li> </ol>	<ol style="list-style-type: none"> <li>1. Flush the column</li> <li>2. Air condition the room</li> </ol>	

## Common Column Problems

OBSERVED PROBLEM	COMMON CAUSE	ACTION TO TAKE	NOTES
Loss of Resolution	<ol style="list-style-type: none"> <li>1. Column worn out</li> <li>2. Guard column dirty</li> <li>3. Pre-column filter dirty</li> <li>4. Bad tubing connection: wrong style nut, too large tubing, wrong type union</li> </ol>	<ol style="list-style-type: none"> <li>1. Replace any pre-column filters</li> <li>2. Flush or replace guard column</li> <li>3. Flush column</li> <li>4. Replace column</li> </ol>	<p>A: Usually only the guard column is dirty</p> <p>B: Always use ZDV when making any connections</p>
Poor Peak Shape - General	<ol style="list-style-type: none"> <li>1. Column worn out</li> <li>2. Guard column dirty</li> <li>3. Pre-column filter dirty</li> <li>4. Deposits in post-column flow path</li> <li>5. Partial obstruction of flowcell</li> <li>6. Too strong a solvent</li> <li>7. Too large a sample injected.</li> <li>8. Reagent flow rate too high.</li> <li>9. Improper tubing connection.</li> </ol>	<ol style="list-style-type: none"> <li>1. Start by replacing filter, then guard.</li> <li>2. Replace column as last resort.</li> <li>3. If new tubing connections have been made, check connections.</li> </ol>	<p>A: Send a chromatogram to Pickering Laboratories' Technical Support Department</p> <p>B: Improper tubing connections are: wrong style nut, too large tubing, wrong type union, improper swaging of ferrule.</p> <p>C: Reverse and flush ion-exchange column at elevated temperature</p>
Reagent backflows into column	<ol style="list-style-type: none"> <li>1. Improper Shutdown procedures</li> <li>2. Improper maintenance procedures</li> <li>3. Leaking fittings between column and HPLC pump</li> </ol>	<p>If NaOH is on column, follow the cleaning procedure</p> <p>If organic solvent is on the Glyphosate column, follow cleaning the procedure</p> <p>If Reagent backflows onto column, follow the procedure below</p>	
High Column pressure	<ol style="list-style-type: none"> <li>1. Blocked pre-column filter or column inlet tubing</li> <li>2. Guard column is blocked.</li> <li>3. Worn HPLC seal or rotor seal.</li> <li>4. Particulate matter in eluant reservoirs</li> <li>5. Column is damaged</li> <li>6. Organic solvent in ion exchange column</li> <li>7. NaOH on Carbamate column</li> <li>8. Excessive eluant flow rate through column</li> </ol>	<ol style="list-style-type: none"> <li>1. For reagent back-flow onto column, see below.</li> <li>2. If the column back-pressure is high (&gt; 2000psi), isolate the source of the high pressure and replace appropriate part &gt;3000psi (214 bars)</li> </ol>	<p>Unfiltered samples Pressure from filter and guard should be &lt; 350psi).</p> <p>Organic contaminants can be washed off carbamate column by first washing with methanol then with dichloromethane. Wash again with methanol before use</p>

## Application Specific Troubleshooting

### CARBAMATES

Grease deposits in the heated reactor	Fatty samples used in carbamate analysis.	Follow the cleaning procedure	
---------------------------------------	---	-------------------------------	--

### GLYPHOSATE

Glyphosate peak is a doublet	Improperly buffered samples	Add 2–4 µL Glyphosate RESTORE to the sample	RESTORE Cat. No. 1700-0140
Glyphosate and AMPA peaks are late and broad	1. Iron contamination of Column 2. Extremely large ID injection loop	Follow the procedure for pumping RESTORE through the column	Replace the large ID loop with a smaller ID.
Glyphosate peak too small or gone, but AMPA present	1. Oxidizing reagent too weak, too old, 2. NaOCl stock solution too old 3. Reactor at wrong temperature	Make fresh Oxidizing reagent	
AMPA peak disappears, but Glyphosate present	Oxidizing reagent too strong	Make fresh Oxidizing reagent	

## Reagent Pump Troubleshooting

YOU NOTICE	THIS MAY MEAN	POSSIBLE CAUSE	YOU SHOULD
1. Uneven pressure trace. 2. Pressure drops. 3. No flow out the outlet check valve.	1. Bubble in check valve. 2. Leaks in system. 3. Dirty check valve. 4. Bad check valve.	1. Fittings are not tight. 2. Particles from worn piston seal caught in check valve.	1. Re-prime pump or try vacuum priming 2. Check connections for leaks by tightening fittings. 3. Prime the system directly from the outlet check valve. 4. Clean or replace the check valves.
1. Uneven pressure trace. 2. Pressure drops. 3. Fluid between the pump head and the retainer.	1. Leaks in system. 2. The piston seal or diaphragm is worn.	1. Fittings not tight. 2. Long usage time since last seal / diaphragm change. 3. Salt deposits on seal or diaphragm	1. Check all connections for leaks. 2. Replace piston seal & diaphragm. 3. Check the piston for salt deposits. Clean as necessary.
Pump makes a loud clanging or slapping noise (intermittent contact with cam).	Piston carrier is catching in piston guide.	1. Screws on the pump head are loose. 2. Seal(s) are worn. 3. Piston guide is worn	1. Screws on pump head. Tighten if necessary. 2. Replace seals. 3. Replace piston guide and seals.
Blue dye in mobile phase.	Pulse damper diaphragm has burst.	Sudden pressure drop when purging system.	Replace pulse damper.
PEEK fittings or components leak.	You cannot force PEEK parts with interference to seal by brute force tightening.	1. Film of fluid between surfaces. 2. Salt crystals between surfaces. 3. Scratches in mating surfaces.	1. Clean and dry mating surfaces. 2. If scratched, replace defective part.

---

## Common Chromatography Problems

### Procedures

To clean the reactor, start by setting the HPLC to a flow rate that is low enough to ensure that the over-pressure relief valve remains closed.

Depending on what you suspect may be causing the blockage, you should use either a methanol solution, or a 20% nitric acid solution. See below for more details.

Usually, however a methanol solution is enough to clean the reactor.

#### **TO REMOVE SILICA DEPOSITS FROM REACTOR**

If NaOH backflows onto a carbamate column, it can dissolve the silica and cause it to flow into the post-column reactor. Silica deposits are too hard to remove. Replace the reactor(s). Carefully clean or replace other components in the flow path. You must remove all the silica before the system will work again. This will probably entail major repair.

#### **TO REMOVE MINERAL DEPOSITS IN THE REACTOR FROM HARD WATER**

Mineral deposits from hard-water samples or reagents can usually be dissolved by pumping 20% nitric acid through the reactor. The Pickering pumps and most (but not all) HPLC pumps will tolerate this. Columns and autosamplers probably will not tolerate this.

- 1) Start HPLC pump at  $< 0.5$  mL/min (100% H<sub>2</sub>O).
- 2) Replace both post-column reagents with deionized water. Run post-column pumps for 5–10 min.
- 3) Stop post-column pumps. Replace deionized water with 20% nitric acid and run post-column pumps for 10–15 min.

Note: Do not run 20% nitric through column or stainless steel restrictor.

- 4) Reverse the order of washing with water and then replace with the post-column reagents.

Note: The washing solution can be stored in Erlenmeyer flasks or spare bottles. Pressurizing the washing solution is not necessary.

**TO REMOVE GREASE DEPOSITS**

Grease deposits (as can be found in vegetation samples) can be dissolved by turning off the post-column pumps and pumping methanol through the HPLC system. Stronger solvents such as acetone, methylene chloride, or tetrahydrofuran (THF) may be needed. If methylene chloride is used, be certain to flush the system thoroughly with methanol before and after because methylene chloride is not miscible with water. There is no need to disconnect the carbamate column.

**IF REAGENT BACKFLOWS ONTO GLYPHOSATE COLUMN**

This procedure usually works but may not work every time.

- 1) Shut down the Vector PCX and remove the analytical and guard columns.
- 2) Flush out all organic solvents from the LC and injector.
- 3) Reverse and flush both columns with regenerant. Use a very slow flow rate so that the back pressure does not exceed 2000 psi.
- 4) Keep flushing until the pressure drops. Keep raising the flow rate until the pressure is normal at 0.40 mL/min and 55°C.
- 5) Reinstall the analytical (in reversed-direction) and guard column (normal direction) and test them.

**IF NAOH IS ON REVERSED-PHASE COLUMN**

1) Do not restart the system. Dissolved silica or C18 phase will re-precipitate in the post-column reactors, or flowcell. These additional complications then require replacement of both reactor coils as well as your column.

**Note:** Complete steps 2–4 as quickly as possible because the longer the hydroxide stays inside the column, the less chance that the column will survive.

- 2) Immediately depressurize the post-column system by loosening the inlet fitting to the deector.
- 3) Disconnect the outlet of the column.
- 4) Restart the HPLC pump to flush the column with 100% MeOH for 20 minutes.
- 5) Catch the effluent from the column with paper towels. Alternatively, connect the outlet of the column to a piece of spare tubing directing the effluent to waste.
- 6) Turn off the HPLC pump and reconnect the outlet of the column and the detector fitting.
- 7) Turn on the HPLC and post-column system and run a calibration standard. Pay special attention to the first four peaks. If these four peaks are not resolved, the column needs to be replaced.

**TO REMOVE IRON CONTAMINATION FROM COLUMN**

Flush guard and column with the Glyphosate Restore solution.

**TO PUMP RESTORE THROUGH THE GLYPHOSATE COLUMNS**

Usually only the guard column is contaminated. We suggest you buy a spare guard column to minimize down-

---

time.

- 1) Remove the analytical column after ensuring no residual post-column pressure.
- 2) Reverse the guard column and pump RESTORE through the guard at 0.4 mL/min for a minimum of 15 min, directing the effluent to waste.
- 3) Pump K200 eluant through the guard long enough to displace RESTORE.
- 4) Reconnect the column and guard in the normal directions and restart the HPLC and post-column systems.

#### VACUUM PRIMING

Sometimes the reagent pump may be very difficult to prime. This can happen after a pump has been shipped, serviced, stored for a long time, or after putting a new bottle of reagent on. Almost always this is due to a trapped bubble inside the pump. Stubborn bubbles can most often be removed using Vacuum Priming:

1. Connect the 20mL priming syringe to the bypass valve. Open the bypass valve.
2. Close the blue Reagent valve on the reagent reservoir cap.
3. Pull a vacuum with the syringe. Hold the vacuum until no more bubbles come out. This causes the trapped bubbles to expand
4. While still holding a vacuum, open the shut-off valve. This sweeps the expanded bubbles out.
5. Wait until about 5ml of liquid has collected, and then close the bypass valve.



*Section 6*  
**APPLICATIONS**

---

**6.1-1 CARBAMATES**

**6.2 GLYPHOSATE**

**6.3 AMINO ACIDS**



---

## CARBAMATES

- 6.1-1 Introduction
- 6.1-1 Background
- 6.1.3 Basic Sample Preparation
- 6.1-4 Reagent Preparation
- 6.1-6 Post-column Conditions
- 6.1-6 Analytical Procedure
- 6.1-6 Sample Chromatograms and Gradient Programs
- 6.1-11 Precautions

### Introduction

High-performance liquid chromatography (HPLC) with post-column derivatization is a technique for rendering analytes more detectable than they would otherwise be in their native forms. Post-column derivatization can give improved sensitivity or better selectivity (reduction of interference) leading to lower detection limits.

The Pickering Laboratories Vector PCX was developed to facilitate the determination of carbamate insecticides, meeting or exceeding performance requirements for precision and accuracy of U.S. Environmental Protection Agency (USEPA) Method 531.1 and 531.2, and the AOAC International Protocol 29.A05:

- High sensitivity: detection limits of 0.1–0.5ng (or 0.2–1ppb levels for drinking water) can be routinely achieved.
- Selectivity (specificity): only N-methylcarbamates and N-methyl carbamoyloximes plus components reactive to OPA under the specified operating conditions are detected.
- Minimum sample preparation: drinking water can be directly injected into the HPLC after filtration. No pre-extraction or sample cleanup is required.
- The analysis is easily automated for unattended analyses with the addition of an autosampler.

There are a number of carbamate pesticide compounds employed worldwide which are not included in the 10 compounds mandated by USEPA Method 531.1 and AOAC Protocol 29.A05. The Pickering Laboratories Carbamate column can separate as many as 23 compounds.

### Background

Carbamates, a class of highly effective commercial insecticides, are used worldwide to protect crops from insect pests. Applied directly to food crops such as grains, fruit, and vegetables, carbamates may seep into drinking water sources through agricultural runoff. In addition, if food crops are harvested too soon after application, residues of carbamates and their by-products may remain in the produce. The use of carbamate insecticides has

created a requirement for a simple, reliable, and sensitive method of residue analysis for these compounds found in vegetable matter, drinking water, and industrial waste-water.

The USEPA Methods 531.1 and 531.2, and the AOAC International protocol 29.A05, describe a direct-inject method which employs gradient liquid chromatography with fluorescence detection, accomplished by post-column hydrolysis and derivatization of the eluted carbamates.

The general structure of the carbamate insecticides is an N-methyl substituted urethane with the variation in the ester moiety. The structural formulas are shown in Figure 6.3-A.

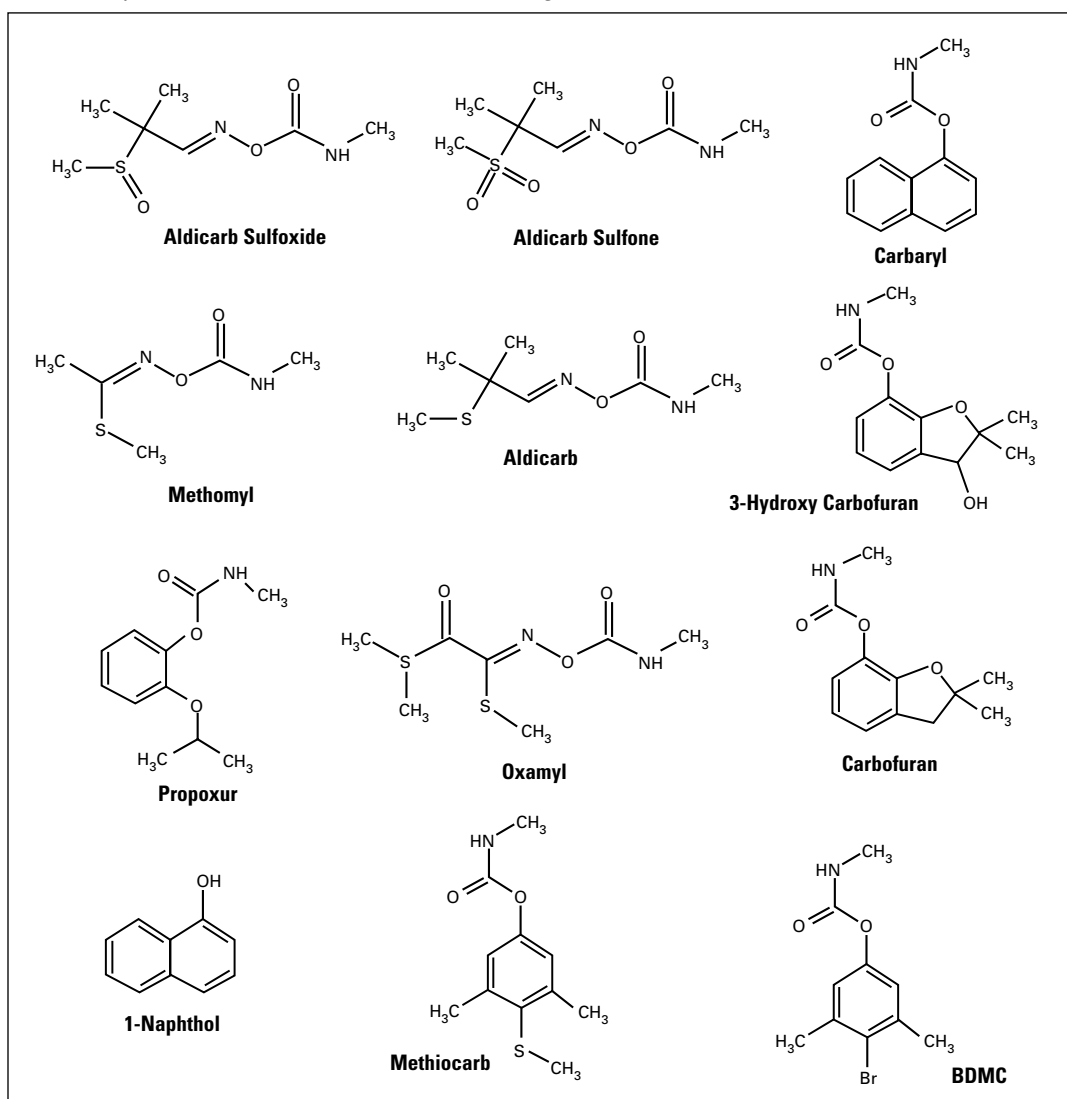

Figure 6.3-A



**FOR VEGETABLE SAMPLES**

Extract the carbamates in ACN  
Reconstitute in methanol  
Filter through a 0.45µm membrane filter

**FOR WATER SAMPLES*****Sampling Protocol***

To preserve the Carbamates in water, this procedure should be carried out in the field.

**EPA SAMPLING PROTOCOL**

1. Add 1.8 ml of ChlorAC Buffer to each pre-cleaned 60 ml sample vial (see note about well and river waters!)
2. If the water sample is chlorinated, dechlorinate with 5 mg of Sodium thiosulfate per 60 ml sample.
3. Fill the sample vials with the dechlorinated water, seal, and mix well.
4. Refer to method EPA 531 or 531.2 for sample transportation and storage details.

***Sample Preparation***

Filter 2ml of sample through a 0.45µm filter.  
Inject 200-400µl.

**FOR STANDARDS AND BLANKS**

Use 10 ml ChlorAC Buffer diluted to 1000 ml with HPLC-grade water.

*Note:* Well and river waters contain colloidal iron which would dissolve if samples are preserved prior to filtration only to precipitate out again as the hydroxide in the reactor. For well and river waters, it is recommended to filter the water first through a 0.45µm filter, and then preserve with ChlorAC™.

**Reagent Preparation**

The two derivatization reagents required for carbamate analysis are a hydrolysis reagent (NaOH) and *o*-phthalaldehyde reagent.

*Note:* During initial installation, the reagent bottles, lines, and pump should first be cleaned and primed with methanol to reduce possible fluorescence background.

**REAGENT 1, HYDROLYSIS REAGENT**

Turn off the inert gas

---

Thoroughly wash the two reagent reservoirs and then rinse with methanol. Wipe down the dip tubes with methanol and a clean cellulose tissue.

The hydrolysis reagent does not require preparation. Pour the hydrolysis reagent (Cat. No. CB130 or CB130.2) directly into the reagent reservoir for Reagent 1. It should be labeled Hydrolysis Reagent. Put the cap on the reservoir. Close the vent valve.

The Hydrolysis reagent remains stable indefinitely.

*Note:* The preparation of the Hydrolysis Reagent by the user is not recommended because it is hard to obtain NaOH of adequate purity.

#### **REAGENT 2, OPA REAGENT**

Pour 945ml of the OPA Diluent (Cat. No. CB910) into the reagent reservoir. Save approximately 5ml.

Put the cap on the bottle, open the vent valve, and turn on the gas supply. Thoroughly de-aerate the contents by sparging with inert gas. Continue bubbling for at least 10 minutes

Dissolve 100 mg of OPA (Cat. No. O120) in approximately 10 ml of HPLC-grade methanol in a clean, dry container.

Turn off the gas supply and remove the cap from the bottle. Add the OPA solution to the deoxygenated Diluent in the reservoir.

Dissolve 2 g of Thiofluor™ (Cat. No. 3700-2000) in the reserved 5 ml of the OPA diluent and add into the reservoir.

Replace the cap and turn on the gas flow. Continue sparging for another minute. Close the vent valve. Gently swirl the reagent to complete the mixing.

*Note:* The preparation of the OPA Diluent by the user is not recommended because sodium borate (any grades) contains excessive amounts of heavy metal contaminants and insoluble matter. These impurities will eventually precipitate in the reactor and flowcell. The one year warranty does not cover damage caused by these contaminants.

The OPA reagent is sensitive to air oxidation and degrades over time. When the OPA reagent reservoir is maintained under inert gas pressure, the OPA reagent maintains its activity for up to two weeks without significant loss of activity.

---

## Post-column Conditions

These are the recommended post-column conditions for carbamate analysis. For the HPLC conditions, refer to the section titled Sample Chromatograms and Gradient programs.

Reagent 1: CB130 or CB130.2, Hydrolysis Reagent (NaOH)

Reagent 2: *o*-Phthalaldehyde and Thiofluor™ in CB910 Diluent

Pump 1 Flow Rate: 0.30 ml/min

Pump 2 Flow Rate: 0.30 ml/min

Reactor 1 Volume: 500 µl

Reactor 2 Volume: 100 µl

Reactor 1 Temp: 100°C

Reactor 2 Temp: Ambient

## Analytical Procedure

Allow the column to equilibrate for about 20 minutes under initial conditions.

Inject 10µl of Carbamate Test Mixture (or the appropriate volume of your standard), and collect the first chromatogram.

## Sample Chromatograms and Gradient Programs

The Peak Names apply to all chromatograms in this section.

- |                                 |                            |
|---------------------------------|----------------------------|
| 1. Aldicarb sulfoxide (Standak) | 7. Propoxur (Baygon)       |
| 2. Aldicarb sulfone             | 8. Carbofuran (Furadan)    |
| 3. Oxamyl (Vydate)              | 9. Carbaryl (Sevin)        |
| 4. Methomyl (Lannate)           | 10. 1-Naphthol             |
| 5. 3-Hydroxy carbofuran         | 11. Methiocarb             |
| 6. Aldicarb (Temik)             | 12. BDMC internal standard |

Carbamate Test Mix, 10ul injection, 25cm, Carbamate C<sub>8</sub> Column (0840250)

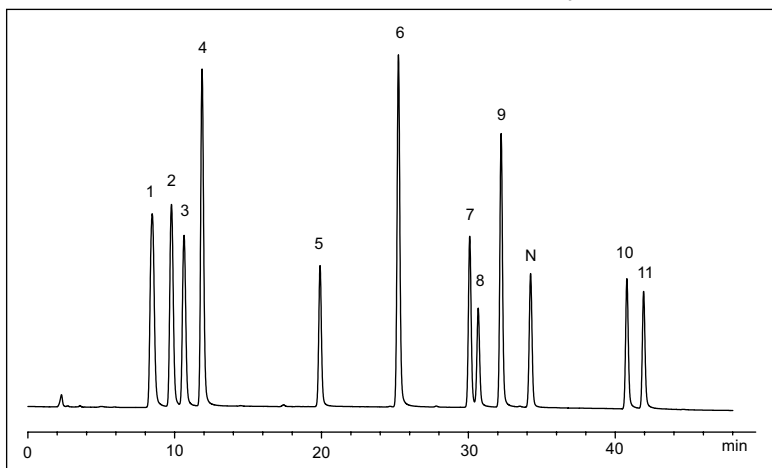

Water Sample, 0.25ppb, 150ul injection, 25cm, Carbamate C<sub>8</sub> Column (0840250)

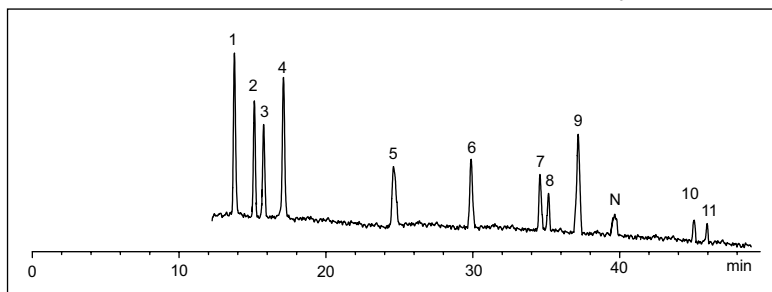

0840250 C<sub>8</sub> COLUMN (4.0 MM ID X 250 MM) WITH METHANOLIC SAMPLES

HPLC Flow Rate: 0.8ml/min Column Temperature: 37° C

Step	Times(min)	Interval	%Water	%MeOH	Comment
Equil.			88	12	0.80 ml/min
0	0-2	2	88	12	inject up to 10 µl methanolic sample
1	2-42	40	34	66	linear gradient
2	42-46	4	34	66	isocratic
4	46.1	0.1	0	100	step change
5	46.1-49	2.9	0	100	cleanout
6	49-	10-13	88	12	re-equilibration

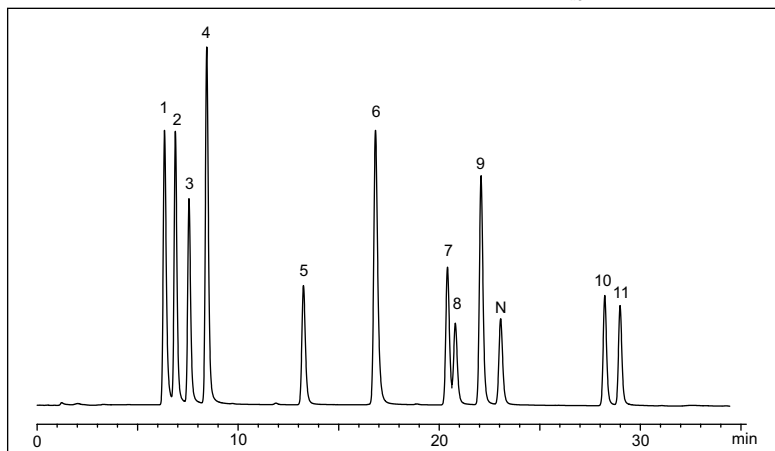
Carbamate Test Mix, 10ul injection, 15cm, Carbamate C<sub>18</sub> Column (1846150)1846150 C<sub>18</sub> COLUMN (4.6 MM ID X 150 MM) WITH METHANOLIC SAMPLES

HPLC Flow Rate: 1.0ml/min Column Temperature: 42° C

Step	Times(min)	Interval	%Water	%MeOH	Comment
Equil.			82	18	1.0 ml/min
0	0	0	82	18	inject up to 10 µl methanolic sample
1	0–0.5	0.5	82	18	isocratic
2	0.5–29	28.5	30	70	linear gradient
4	29.1	0.1	0	100	step change
5	29–31	2	0	100	Cleanout
6	31–	5–8	82	18	re-equilibration

Carbamate Test Mix, 10µl injection, 25cm, Carbamate C<sub>8</sub> Column (0846250), Aqueous Gradient Program

0846250 C<sub>8</sub> COLUMN (4.6mm x 250mm) FOR WATER SAMPLES

HPLC Flow Rate: 1.0mL/min Column Temperature: 42°C

Step	Time (min)	Interval	% Water	% MeOH	Comment
Equil.			100	0	Equilibration
1	0	0	100	0	Inject 400 µL water sample
2	1	1	100	0	Concentrate sample on column
3	1.1	0.1	82	18	Step change
4	36	35	30	70	Linear gradient
5	39	3	30	70	Isocratic
6	39.1	0.1	0	100	Step change
7	41	2	0	100	Cleanout
8	41.1	0.1	100	0	Step change
9	55		100	0	Re-equilibration

Carbamate Test Mix, 10 $\mu$ l injection, 25cm, Carbamate C<sub>8</sub> Column (0846250)

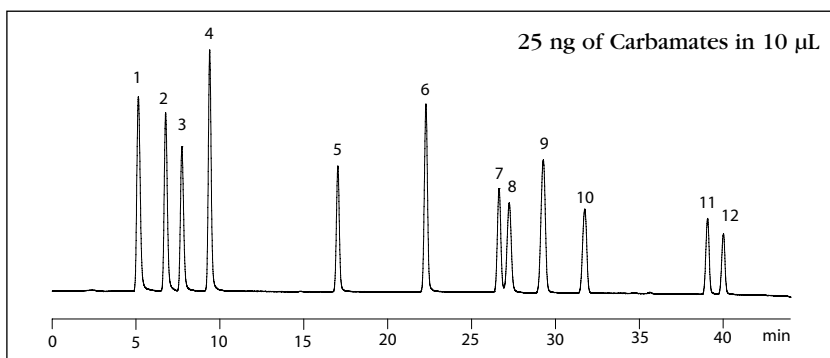

0846250 C<sub>8</sub> COLUMN (4.6 MM ID X 250 MM) WITH METHANOLIC SAMPLES

HPLC Flow Rate: 1.0ml/min Column Temperature: 42° C

Step	Times(min)	Interval	%Water	%MeOH	Comment
Equil.			85	15	1.0 ml/min
0	0	0	85	15	inject up to 10 $\mu$ l methanolic sample
1	0-1	1	80	20	isocratic
2	1-44	43	25	75	linear gradient
4	44.1	0.1	0	100	step change
5	44.1-49	5	0	100	cleanout
6	49-	5-8	85	15	re-equilibration

Upon completion of the analysis, follow the shutdown procedure described in Section 4. Store the carbamate column in 100% Methanol

*Note:* The inert gas should be left on to preserve the OPA reagent. Close the blue reagent valve on the reservoir to prevent siphoning of the reagent when not in use.

---

## Precautions for Carbamate Analysis

Always wear gloves during the preparation of the reagents. The OPA and Thiofluor™ can cause skin irritation.

- The OPA reagent is sensitive to air oxidation, degrades over time, and should be prepared fresh for optimum sensitivity. OPA reagent maintains its activity for up to two weeks when pressurized with inert gas.
- Thiofluor™ is extremely hygroscopic. Always keep in a tightly closed container.
- The preparation of the OPA Diluent by the user is not recommended because sodium borate (any grades) contains excessive amounts of heavy metal contaminants and insoluble matter. These impurities will eventually precipitate in the reactor and flowcell. The one year warranty does not cover damage caused by these contaminants.
- Use HPLC-grade methanol and water (Fisher Scientific, JT Baker, or Merck) for carbamate analysis to avoid problems with baseline drift, spurious peaks, and noise.
- Use bottled HPLC-grade water if possible (Fisher Scientific, JT Baker, or Merck), especially during the initial system start-up. If water from a water purification system is used, ensure the system has an activated charcoal unit to eliminate organics, and that the charcoal cartridge is placed after the ion-exchange cartridges. (Many ion-exchange resins leach out OPA-positive contaminants that cause unacceptable fluorescence background.)
- The water in the solvent reservoir should be changed every 3 to 4 days to prevent possible bacterial growth.
- The test mixture for carbamate is for qualitative use only. It is not recommended for calibration purposes.
- Filter all samples through a 0.45µm membrane filter. Some samples may require even more stringent filtration, especially if colloids are present.
- Aqueous samples must always be properly buffered. Consult EPA Method 531.2 for details.
- For carbamate analysis with methanolic samples, inject – 10µl. Large amount of organic solvents can cause peak distortion.
- For small aqueous sample volumes (< 20µl) either of the two Pickering columns can be used. For volumes greater than 300µl, use only the 25cm column. A gradient delay time should be programmed into the analysis (0% organic) to trap the sample onto the head of the column.
- Avoid purging the system with 100% acetonitrile as precipitation of borate salt in the reactor might occur. Do not exceed 70% acetonitrile if it will be used as the mobile phase.
- Do not store the column in water.
- Use the Pickering Laboratories carbamate analysis column, which is specifically designed and tested for the separation of carbamates in the EPA Methods.



---

## GLYPHOSATE

- 6.2 Introduction
- 6.2-1 Background
- 6.2-1 Basic Sample Preparation
- 6.2-2 Reagent Preparation
- 6.2-4 Analytical and Post-column Conditions
- 6.2-4 Analytical Procedure
- 6.2-5 Sample Chromatograms
- 6.2-6 Precautions

### Introduction

High-performance liquid chromatography (HPLC) with post-column derivatization is a technique for rendering analytes more detectable than they would otherwise be in their native forms. Post-column derivatization can give improved sensitivity or better selectivity (reduction of interference) leading to lower detection limits.

The Pickering Laboratories Vector PCX was developed to facilitate the determination of the herbicide glyphosate (and its metabolite AMPA), meeting or exceeding performance requirements for precision and accuracy of USEPA Method 547.

Glyphosate (N-Phosphonomethylglycine, Rodeo™, Roundup™) is a broad-spectrum herbicide. Its wide use in agriculture can result in its presence in ground water. A sensitive analytical technique has been developed to monitor levels of glyphosate and its principal metabolite, aminomethylphosphonic acid (AMPA). This method is an improved version of USEPA Draft Method 547.

The Pickering Post-column method can also be used for the determination of Glyphosate and AMPA in plants and soils. Pickering has developed an improved sample preparation procedure for vegetable samples. It is a simple extraction followed by clean-up on a strong cation-exchange cartridge. The procedure is listed later on in this chapter.

## Background

Glyphosate and AMPA are separated on a strong cation-exchange column (fully sulfonated, cross-linked polystyrene, mixed  $K^+/H^+$  form). After isocratic separation, the column is regenerated with dilute KOH, then re-equilibrated with eluant.

Fluorometric detection follows a two-stage post-column reaction. In the first stage, glyphosate is oxidized by hypochlorite to glycine. In the second stage, glycine reacts with *o*-phthalaldehyde and Thiofluor™ (a mercaptan) at pH 9–10 to produce a highly fluorescent isoindole. AMPA does not need the initial oxidation to react with OPA (Figure 6.4-A); indeed oxidation reduces its fluorescent yield.

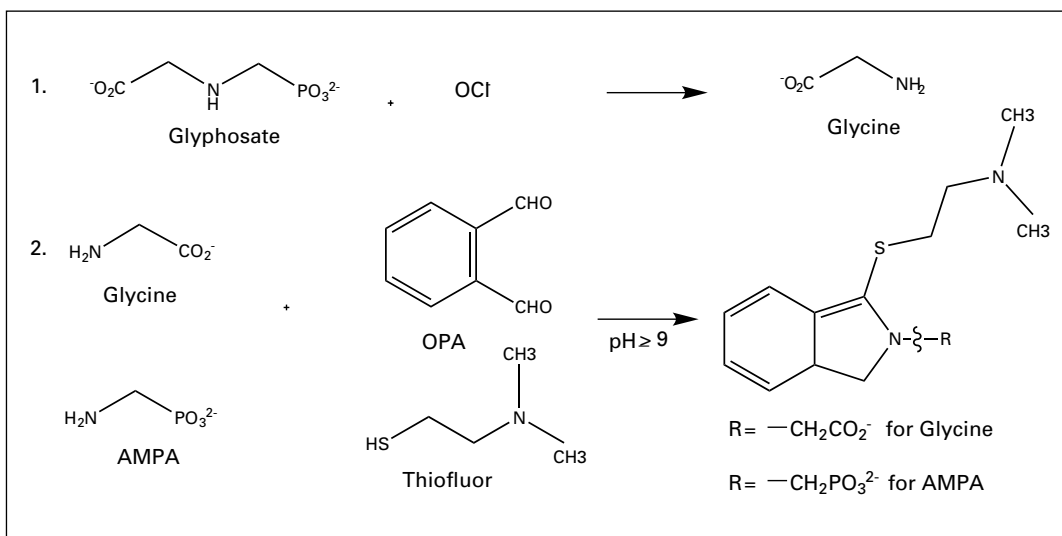

Figure 6.4-A

## Basic Sample Preparation

The following is a suggested basic sample preparation for Vegetable and Water samples containing glyphosate. The method for Vegetables is different from the procedure called out by the AOAC. We have developed ion-exchange cartridges, which we have fully qualified in our lab, and which greatly improve the ease and reproducibility of the extraction while at the same time reducing many of the trouble aspects of the original published method (e.g. iron contamination).

### FOR VEGETABLE SAMPLES

#### Extraction

To 25g of a homogenous sample add enough water (after estimation of moisture content) to make the total volume of water 125 ml. Blend at high speed for 3-5 min. and centrifuge for 10 min. Transfer 20 mL of

the aqueous extract into a centrifuge tube and add 15 mL of methylene chloride (to remove nonpolar co-extractives). Shake for 2-3 min. and centrifuge for 10 min. Transfer 4.5 mL of the aqueous layer into a vial and add 0.50 mL acidic modifier solution (16g  $\text{KH}_2\text{PO}_4$ , 160 ml  $\text{H}_2\text{O}$ , 40 ml Methanol, 13.4 ml HCl). Shake and centrifuge for 10 min.

#### **Matrix specific modification**

Plants with high: 1) Water 2) Protein 3) Fat Content

- 1) For crops that absorb large amounts of water, reduce test portion to 12.5g keeping water volume the same.
- 2) For crops that have high protein content add 100  $\mu\text{l}$  HCl to 20 ml aliquot of crude extract. Cap, shake and centrifuge for 10 min.
- 3) For crops that have high oil content, do the methylene chloride partition twice.

#### **Cation-exchange cleanup**

Transfer 1 mL of extract (representing 0.18g normal crop or 0.09g dry crop) to the column reservoir and elute to the top of the resin bed. Add 0.70 mL of the elution solution (160 mL  $\text{H}_2\text{O}$ , 2.7 mL HCl, 40 mL Methanol) and discard the effluent. Repeat with a second 0.70 mL portion and discard effluent. Elute with 12 mL of the elution solution and collect in a round-bottomed flask. Evaporate to dryness in a water bath set at 40°C using a rotary evaporator. Or collect in a centrifuge tube and evaporate using a vacuum vortex evaporator. Dissolve residue in 2.0 mL of the elution solution (use 1.5 ml for dry crops). Extracts before evaporation can be stored refrigerated for up to 7 days.

#### **FOR WATER SAMPLES**

Filter water through a 0.45 $\mu\text{m}$  membrane filter, and inject 200-400  $\mu\text{l}$ .

If the glyphosate comes out as a doublet, add 2 drops of Restore directly to the sample vial.

## **Reagent Preparation**

### **HYPOCHLORITE REAGENT**

*Note:* 5% Sodium hypochlorite must be used for preparing oxidizing reagent (can be obtained from local grocery stores)

Pour 945 ml of the Hypochlorite Diluent (GA116) directly into the reagent reservoir for Pump 1. This should be labeled Oxidizing Reagent.

Add 100  $\mu\text{l}$  of 5% sodium hypochlorite solution to the diluent. The exact amount will depend on the actual hypochlorite concentration of the stock solution. When you get your first

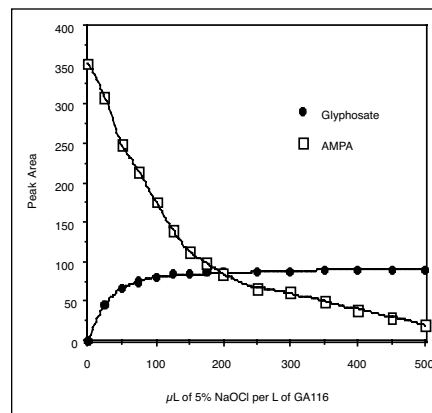

Figure 6.4-B

---

chromatograms, you will be able to adjust the amount to optimize the relative peak areas of glyphosate versus AMPA. Figure 6.4-B shows a typical response curve. Cap the reservoir, close the vent valve, and swirl the solution to mix it thoroughly.

*Note:* The hypochlorite concentration slowly decreases with time. This will manifest itself as a change in the relative peak areas of glyphosate and AMPA. It will remain usable for several days, but we recommend you calibrate daily.

*Caution!* Do NOT use calcium hypochlorite in the oxidizing reagent. This will cause plugging of the post-column reactor. The one year warranty does not cover damage caused by calcium hypochlorite-based reagents. The EPA Draft Method 547 is wrong on this point;  $\text{Ca}_3(\text{PO}_4)_2$  is insoluble in water.

#### **OPA REAGENT**

Pour 945 ml of the OPA Diluent (Cat. No. GA104) into the reagent reservoir for Pump 2. Save approximately 5 ml.

Put the cap on the bottle, open the vent valve, and turn on the gas supply. Thoroughly de-aerate the contents by sparging with inert gas. Continue bubbling for at least 10 minutes.

Dissolve 100 mg of OPA (Cat. No. O120) in approximately 10 ml of HPLC-grade methanol in a clean, dry container.

Turn off the gas supply and remove the cap from the bottle. Add the OPA solution to the deoxygenated Diluent in the reservoir.

Dissolve 2 g of Thiofluor™ (Cat. No. 3700-2000) in the reserved 5 ml of the OPA Diluent and add into the reservoir.

Replace the cap and turn on the gas flow. Continue sparging for another minute. Close the vent valve. Gently swirl the reagent to complete the mixing.

*Caution!* The preparation of the OPA Diluent by the user is not recommended because sodium borate (any grades) contains excessive amounts of heavy metal contaminants and insoluble matter. These impurities will eventually precipitate in the reactor and flowcell. The one-year warranty does not cover damage caused by these contaminants.

*Note:* The OPA reagent is sensitive to air oxidation and degrades over time. The Vector PCX modular system is designed to minimize this oxidation, resulting in a minimal loss of OPA reagent due to oxidation. When the OPA reagent reservoir is maintained under inert gas pressure, the OPA reagent maintains its activity for up to one week without significant loss of activity.

## Analytical and Post-column Conditions

These are the recommended conditions for glyphosate analysis using the 1954150 column and 1953020 guard column.

Column Temperature: 55°C

HPLC Flow Rate: 0.4 ml/min

HPLC Program:

Times (min)	%K200	%RG019
0	100	0
15.0	100	0
15.1	0	100 Regeneration
17	0	100
17.1	100	0
27.0	100	0 Re-equilibration

The exact time of equilibration depends on the internal volume of your HPLC. When the baseline and column pressure are stable for two minutes, the column has been re-equilibrated.

Post-Column Conditions:

Reagent 1: 100 µl of 5% NaOCl in GA116 Diluent

Reagent 2: *o*-Phthalaldehyde and Thiofluor™ in GA104 Diluent

Pump 1 Flow Rate: 0.30 ml/min

Pump 2 Flow Rate: 0.30 ml/min

Reactor 1 Volume: 500 µl

Reactor 2 Volume: 100 µl

Reactor 1 Temp: 36°C

Reactor 2 Temp: Ambient

## Analytical Procedure

Allow the column to equilibrate for about 20 minutes under initial conditions.

Inject 10µl of Glyphosate Text Mixture (or the appropriate volume of your standard), and collect the first chromatogram.

Figure 6.4-C shows a typical Glyphosate and AMPA chromatogram. In a standard with Glyphosate and AMPA at equal concentration, the peak areas should be similar. The peak areas are influenced by the amount of hypochlorite in Reagent 1.

### Sample Chromatograms

Glyphosate Test Mix, 10 $\mu$ l injection

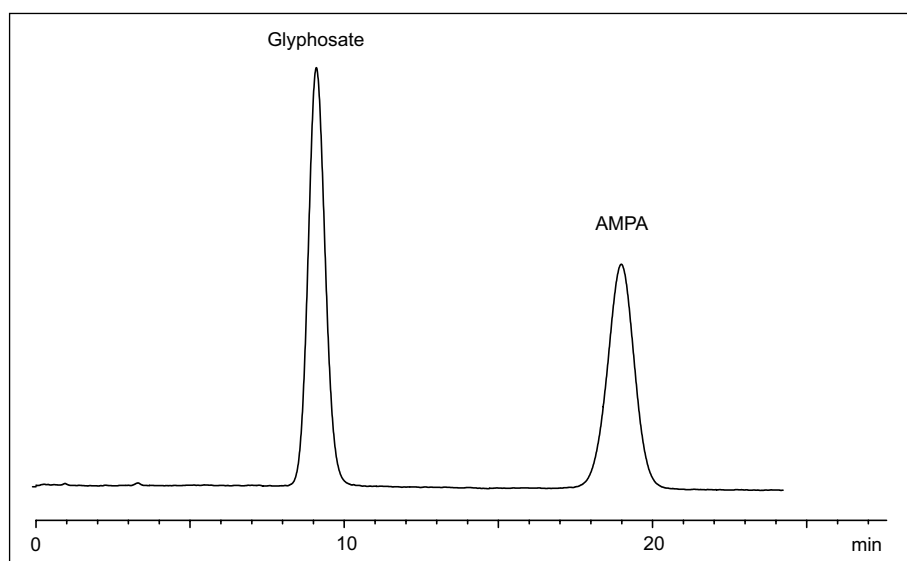

Figure 6.4-C

Glyphosate and AMPA, 13ppb in K200, 100 $\mu$ l injection

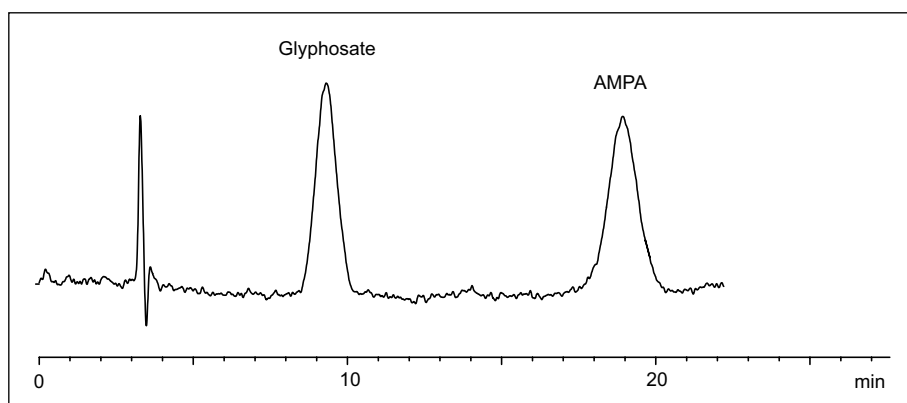

Figure 6.4-D

Broccoli sample spiked with Glyphosate and AMPA, 50 ppb, 100 µl injection

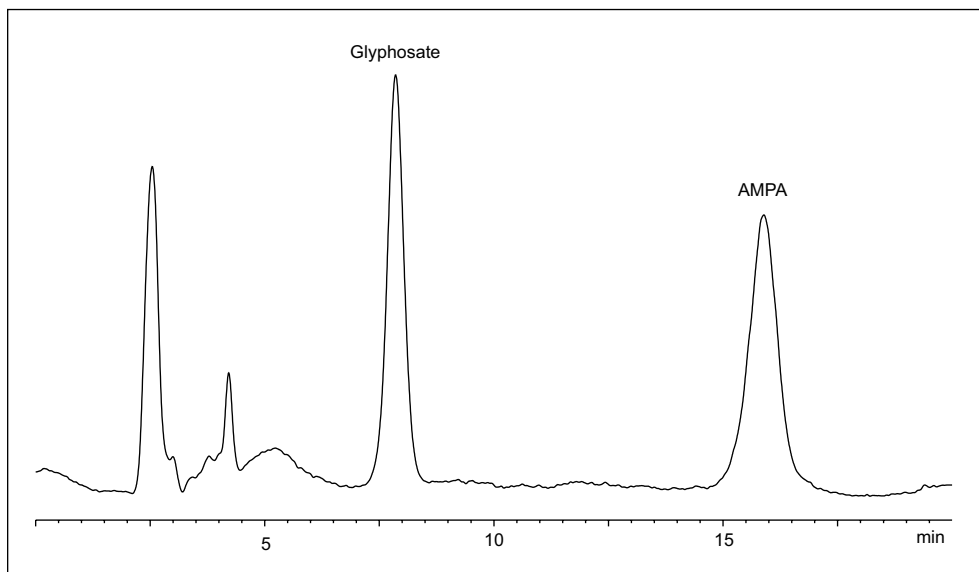

Figure 6.4-E

Upon completion of the analysis, follow the shutdown procedure described in Section 4. Store the column in RG019.

Excessive flushing will require an equally excessive re-equilibration when you start up again.

*Note:* The inert gas should be left on to preserve the OPA reagent. Close the blue reagent valve on the reservoir to prevent siphoning of the reagent when not in use.

### Precautions to be Aware of in Glyphosate Analysis

- Always wear gloves during the preparation of the reagents. The OPA and Thiofluor™ can cause skin irritation.
- The OPA reagent is sensitive to air oxidation, degrades over time, and should be prepared fresh for optimum sensitivity. OPA reagent is stable for at least one week when pressurized with inert gas.
- Thiofluor™ is extremely hygroscopic. Always keep in a tightly closed container.
- The preparation of the OPA Diluent by the user is not recommended because sodium borate (any grades) contains excessive amounts of heavy metal contaminants and insoluble matter. These impurities will eventually precipitate in the reactor and flowcell. The one year warranty does not cover damage caused by these contaminants.

- 
- Contamination usually occurs on the guard column. Wash it separately from the analytical column. This will save much time in the washing and re-equilibration.
  - Contaminants of special concern: iron and other polyvalent cations, organic dyes, surfactants, detergents, and lipids. They may cause irreversible damage.
  - Organic solvents will cause the resin in the column to swell. This leads to high back-pressure and broadened peaks. The column sometimes can be regenerated.
  - Use Pickering eluants with the Pickering column, as they are designed to work together.
  - The test mixture for glyphosate is for qualitative use only. It is not recommended for calibration purposes.
  - Filter all samples through a 0.45µm membrane filter. Some samples may require even more stringent filtration, especially if colloids are present.
  - Aqueous samples must always be properly buffered. Consult EPA Method 547 for details.

---

## AMINO ACIDS

- 6.3** Introduction
- 6.3-1** Background
- 6.3-2** Basic Sample Preparation
- 6.3-3** Reagent Preparation
- 6.3-4** Analytical and Post-column Conditions
- 6.3-5** Procedure
- 6.3-6** Sample Chromatograms and Gradient Programs
- 6.3-13** Precautions

### Introduction

High performance liquid chromatography (HPLC) with post-column derivatization is a technique for rendering analytes more detectable than they would otherwise be in their native forms. Post-column derivatization gives improved sensitivity or better selectivity (reduction of interference) leading to lower detection limits. The Pickering Laboratories Pinnacle PCX was developed to facilitate the determination of amino acids in using sodium ion-exchange or in native samples using lithium ion-exchange columns. There are two options for post-column detection of amino acids. The first is the use of Pickering's patented TRIONE® ninhydrin reagent, which will react with both primary and secondary amino acids. The second is the use of *o*-phthalaldehyde (OPA), a fluorescent reagent that gives greater sensitivity but will detect only primary amino acids.

A complete post-column analysis system for amino acids consists of the following components:

- HPLC ternary or greater gradient pump
- Manual injector or autosampler equipped with high pH compatible Tefzel® or PEEK™ seals
- Pickering Laboratories ion-exchange columns
- Pickering Pinnacle PCX post-column derivatization instrument
- Eluants, reagents, and standards
- Visible or fluorescence detector
- Chart recorder, integrator, or data system

Ion-exchange chromatography followed by post-column derivatization has been the method of choice for amino acid analysis since S. Moore, D.H. Spackman and W.H. Stein published it in 1958—work which merited a Nobel prize.

## Background

The separation is a multi-modal process wherein ion-exchange, ion-exclusion, and partition all take place. The primary process is cation-exchange where a pH gradient mobilizes amino acids in order of their isoelectric points; acidic amino acids such as glutamic acid elute early and basic amino acids such as lysine elute late. Partitioning is affected by ionic strength and organic modifiers; for example threonine and serine are resolved by partition effects. Ion-exclusion only occurs for highly acidic amino acids such as taurine.

Sodium ion-exchange is used for fast analysis of the 22 amino acids found in hydrolyzed protein or in simple formulated products. Lithium ion-exchange is a slower technique with higher resolution to separate as many as 46 amino acids and compounds found in the complex mixtures of biological fluids or tissue extracts.

The most popular reagent for post-column detection is ninhydrin. Ninhydrin reacts with primary amines and hydrindantin to form Ruhemann's Purple (Figure 6.2-A) which is detectable at 570nm. Ninhydrin reacts with secondary amines to form a yellow complex detectable at 440nm. The ninhydrin reaction is carried out at 130°C with a reactor volume of 500 µl. The elevated temperature is required because at room temperature, the ninhydrin reaction is very slow and takes hours to go to completion.

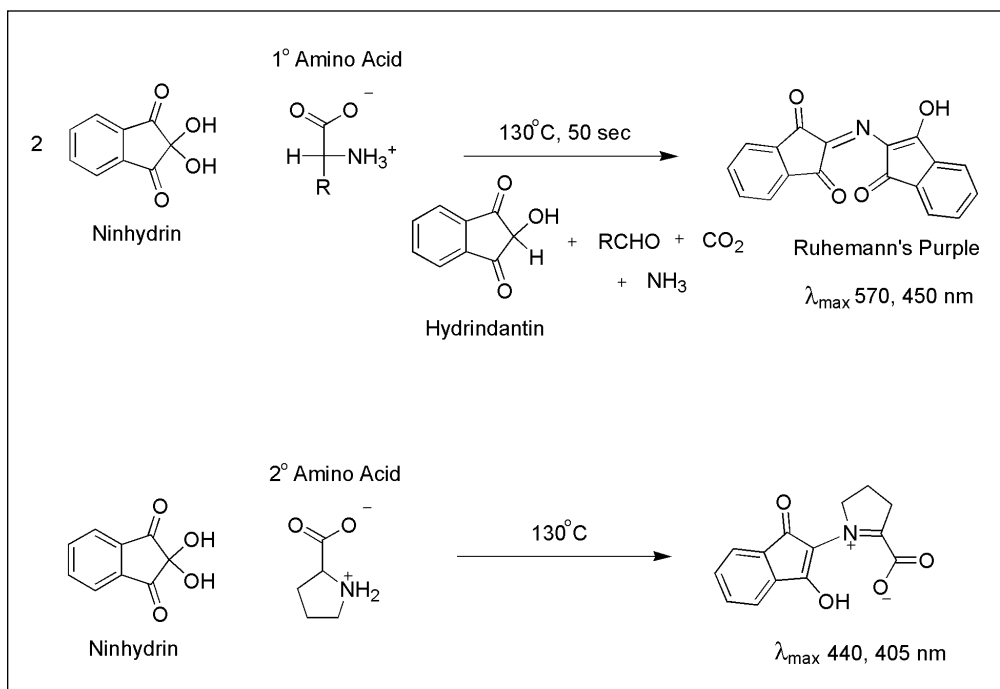

Figure 6.2-A

An alternative reagent system based on *o*-phthalaldehyde (OPA) can be used for high-sensitivity detection of primary amino acids. OPA reacts rapidly with primary amines and Thiofluor™ (N,N-dimethyl-2-mercaptoethylamine) under mild basic conditions to produce a strongly fluorescent isoindole derivative (Figure 6.2-B). OPA does not react with secondary amines or aryl amines, so fails to detect Proline and other secondary amino acids.

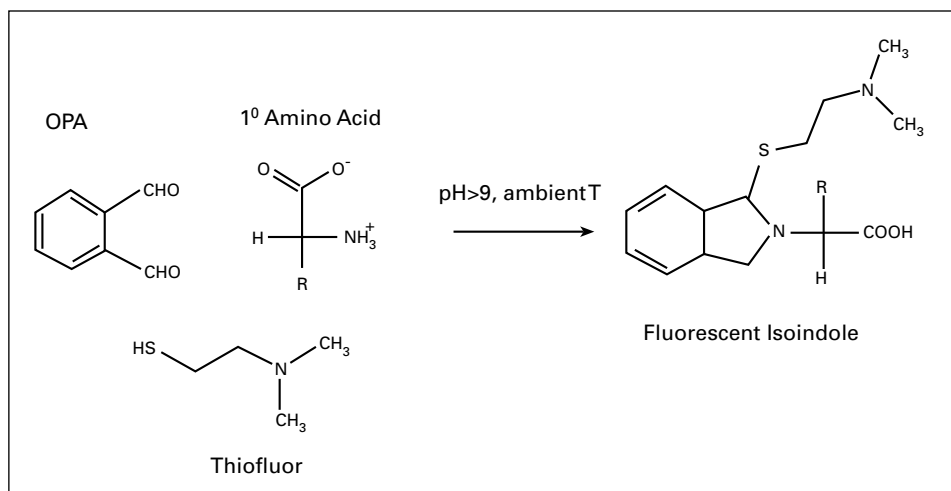

Figure 6.2-B

However, it is possible to detect secondary amino acids by using a two-step reaction in which they are first oxidized and then reacted with OPA. This technique has some disadvantages, and is not often used. Contact Pickering for details.

The Pickering Pinnacle PCX derivatization instrument for fluorescent detection of amino acids is similarly designed to the ninhydrin instrument, except that it contains a 150  $\mu$ l reactor and the reaction is carried out at 45°C.

## Basic Sample Preparation

The following is a general sample preparation for Physiologic Fluid and Protein Hydrolysate samples. There are many more types of samples that can be used for amino acid analysis. For details, consult the AOAC methods and laboratory procedures.

Native amino acids are those found “free” in samples such as serum, urine and other physiological fluids, plant extracts, foods and beverages. Although preparation of these samples for amino acid analysis is much simpler and less time-consuming than protein hydrolysis, control of pH and normality, and removal of soluble protein are critical factors which can affect the chromatography.

The early-eluting amino acids — taurine, urea, aspartic acid, threonine, serine, etc. — are particularly sensitive to pH and normality. Accordingly the samples must be held to a narrow pH range between 2.1 and 2.5, and the proper lithium ion concentration to ensure reproducibility in the early part of the chromatogram. The later-eluting compounds are more tolerant of initial sample conditions, and their retention times are not as likely to be affected. SERAPREP™ and URIPREP™ replace commonly-used protein precipitation reagents such as acetonitrile, perchloric acid and picric acid, and eliminate the need for dialysis, ultrafiltration, and repeated centrifugation steps, followed by pH adjustment.

- Filter all samples through a 0.45µm membrane filter. Some samples may require even more stringent filtration, especially if colloids are present.
- Samples must always be properly buffered. The ideal pH for sample injection is pH 2.3 ± 0.2.
- For native samples, be sure that all proteins have been removed before analysis.

#### **PHYSIOLOGIC FLUID SAMPLES:**

##### **PREPARATION USING SERAPREP™ OR URIPREP™**

Use SERAPREP™ for preparing serum and other samples with a high buffering capacity, e.g. sardine oil. Use URIPREP™ for preparing urine and other samples with low buffering capacity, such as fruit juices, musts and warts. The efficiency of protein precipitation and the need for post-centrifugation pH adjustment of the sample determine which reagent is best for your particular sample.

1. In a microcentrifuge tube thoroughly mix equal portions of sample and SERAPREP™ or URIPREP™.
2. Let stand for 5 minutes. Centrifuge the mixture at 13,000 rpm for 5 minutes. Check the supernate pH to ensure that the range is pH 2.3±0.2. Adjust the initial mixing ratio as necessary.
3. Filter the supernate with a syringe filter (0.2 or 0.45 µm). The filtrate is ready to be injected into an auto-sampler vial for amino acid analysis.
4. If further dilution is needed, use Li 220 to adjust the concentration of analyte.

## **Reagent Preparation**

### **TRIONE PREPARATION**

TRIONE® reagent requires little to no preparation, depending on what type you use.

**T100:** The one-part TRIONE® (Cat. No. T100C) requires no preparation - simply pour the TRIONE® directly into the reagent reservoir and put the cap on the reservoir.

**T200:** To prepare two-part TRIONE® (Cat. No. T200), pour Bottle 1 into the reservoir, add Bottle 2 to the reservoir, and cap tightly under Nitrogen. Swirl until homogeneous.

*Note:* TRIONE® is air sensitive, and must be kept under Nitrogen. The useful lifetime of T100 is three months\* unopened, and one month in the reservoir. The shelf-life of T200 is one year\* unopened, and one month in the reservoir.

\*From date of manufacture.

#### OPA PREPARATION

1. Pour 945ml of the OPA Diluent (Cat.No. OD104) into the reagent reservoir. Save approximately 5 ml for Step 5.
2. Put the cap on the bottle, open the vent valve, and turn on the gas supply. Thoroughly deaerate the contents by sparging with inert gas. Continue bubbling for at least 10 minutes.
3. Dissolve 300mg of OPA (Cat. No. O120) in 10mL of HPLC-grade methanol in a clean, dry container.
4. Turn off the gas supply and remove the cap from the bottle. Add the OPA solution to the deoxygenated diluent in the reservoir. Wash any residual mixture into the reservoir with an additional 1–2 ml of methanol.
5. Dissolve 2g of Thiofluor™ (Cat. No. 3700-2000) in the reserved 5 ml of OPA Diluent and add to the reservoir.
6. Add 3ml of 30% Brij-35® (Sigma) solution.
7. Replace the cap and close the vent valve. Gently swirl the reagent to complete the mixing. Turn on the inert gas.

*Note:* OPA reagent is sensitive to air oxidation and will degrade over time. The Pinnacle PCX system is designed to minimize this oxidation. When the OPA reagent reservoir is maintained under inert gas pressure, the OPA reagent can maintain its activity for up to one week without significant loss of activity.

#### Post Column Conditions

These are the recommended post-column conditions for the most common methods of amino acid analysis. For the HPLC conditions, refer to the section titled Sample Chromatograms and Gradient Programs.

#### USING TRIONE NINHYDRIN REAGENT:

Reagent 1: TRIONE® (Cat. No. T100 or T200)  
Pump 1 Flow Rate: 0.30 ml/min  
Reactor 1 Volume: 500 µl  
Reactor 1 Temp: 130°C

#### USING OPA REAGENT:

Reagent 1: *o*-Phthalaldehyde and Thiofluor™ in OD104 Diluent, plus 35% Brij-35®  
Pump 1 Flow Rate: 0.30 ml/min  
Reactor 1 Volume: 150 µl  
Reactor 1 Temp: 45°C

---

**USING SODIUM HYPOCHLORITE, FOLLOWED BY OPA REAGENT:**

Reagent 1:	250 µl of 5% Sodium Hypochlorite in GA116 Diluent
Reagent 2:	<i>o</i> -Phthalaldehyde and Thiofluor™ in OD104 Diluent, plus 30% Brij-35®
Pump 1 Flow Rate:	0.30 ml/min
Pump 2 Flow Rate:	0.30 ml/min
Reactor 1 Volume:	500 µl
Reactor 2 Volume:	100 µl
Reactor 1 Temp:	55°C
Reactor 2 Temp:	Ambient

**Procedure**

Pickering Laboratories recommends different gradient conditions depending on the column and type of sample. **Use the program recommended on the column data sheet for the initial testing.** Do not change this program until you are sure that the other aspects of the system are functioning properly.

The column oven temperature programming gives additional flexibility when optimizing methods. Using temperature gradient allows to improve separation, shorten analysis time and fine-tune the method for detecting compounds of interest. Please refer to page 4.8 for details on how to set up timetable for the column oven.

Set the maximum pressure limit on the HPLC to 220 bar to protect the column. Allow the column to equilibrate for about 30 minutes under initial conditions. Inject 10µl of the Amino Acid Standard, and collect three chromatograms. The first chromatogram will not be representative of the systems performance, so use the second two to evaluate the performance.

**METHOD 1: 0354100T ISOTHERMIC PHYSIOLOGICAL FLUID LITHIUM (4.0 x 100mm)**  
**GUARD COLUMN: GARD COLUMN TEMP: 37°C HPLC FLOW RATE: 0.35ml/min**  
**REAGENT FLOW RATE: 0.3ml/min INJECTION VOLUME: 10ul**

CONDITIONS				
Time (Min)	Li275 %	Li750 %	RG003 %	Comment
0	100	0	0	Inject
8	100	0	0	Isocratic
46	65	35	0	Linear Gradient
86	0	100	0	Linear Gradient
90	0	100	0	Isocratic
115	0	94	6	Linear Gradient
122	0	94	6	Isocratic
122.1	100	0	0	Step Change
140	100	0	0	Re-equilibration

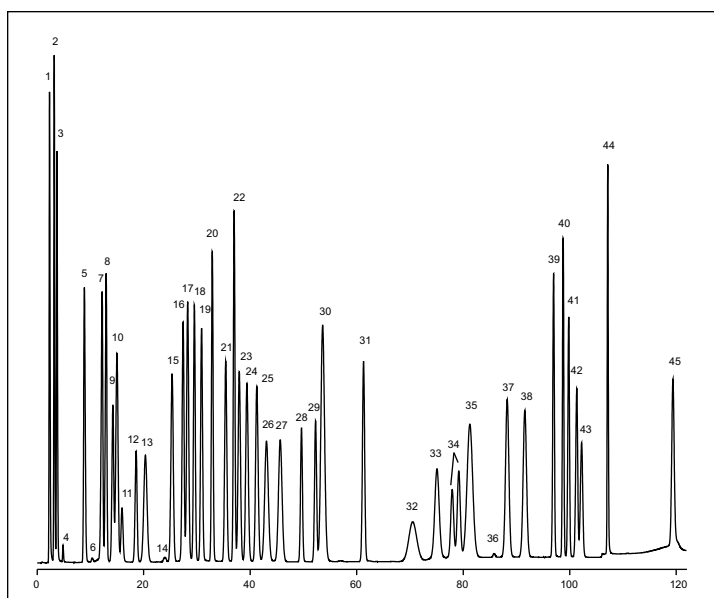

**PEAK IDENTIFICATION**

- |                        |                                    |                                    |                              |
|------------------------|------------------------------------|------------------------------------|------------------------------|
| 1. Phosphoserine       | 13. $\alpha$ -Amino adipic acid    | 25. Norleucine                     | 37. Ornithine                |
| 2. Taurine             | 14. Proline                        | 26. Tyrosine                       | 38. Lysine                   |
| 3. Phosphoethanolamine | 15. Glycine                        | 27. Phenylalanine                  | 39. Histidine                |
| 4. Urea                | 16. Alanine                        | 28. $\beta$ -Alanine               | 40. 3-Methylhistidine        |
| 5. Aspartic acid       | 17. Citrulline                     | 29. $\beta$ -Amino-i -butyric acid | 41. 1-Methylhistidine        |
| 6. Hydroxyproline      | 18. $\alpha$ -Amino-n-butyric acid | 30. Homocystine                    | 42. Carnosine                |
| 7. Threonine           | 19. Valine                         | 31. $\gamma$ -Aminobutyric acid    | 43. Anserine                 |
| 8. Serine              | 20. Cystine                        | 32. Tryptophan                     | 44. $\alpha$ -Amino- $\beta$ |
| 9. Asparagine          | 21. Methionine                     | 33. Ethanolamine                   | guanidinopropionic acid      |
| 10. Glutamic acid      | 22. Cystathionine                  | 34. Hydroxylysines                 | 45. Arginine                 |
| 11. Glutamine          | 23. Isoleucine                     | 35. Ammonia                        |                              |
| 12. Sarcosine          | 24. Leucine                        | 36. Creatinine                     |                              |

**METHOD 2: 0393250 ISOTHERMIC PHYSIOLOGICAL FLUID LITHIUM (3.0 x 250mm)****GUARD COLUMN: GARD****COLUMN TEMP: 40°C****HPLC FLOW RATE: 0.30ml/min****REAGENT FLOW RATE: 0.3ml/min****INJECTION VOLUME: 10ul**

Time(min)	%Li275	%Li750	%RG003	Comment
0	100	0	0	inject
17	100	0	0	isocratic
65	65	35	0	linear gradient
128	0	100	0	linear gradient
145	0	100	0	isocratic
185	0	94	6	linear gradient
185.1	100	0	0	step change
210	100	0	0	re-equilibration

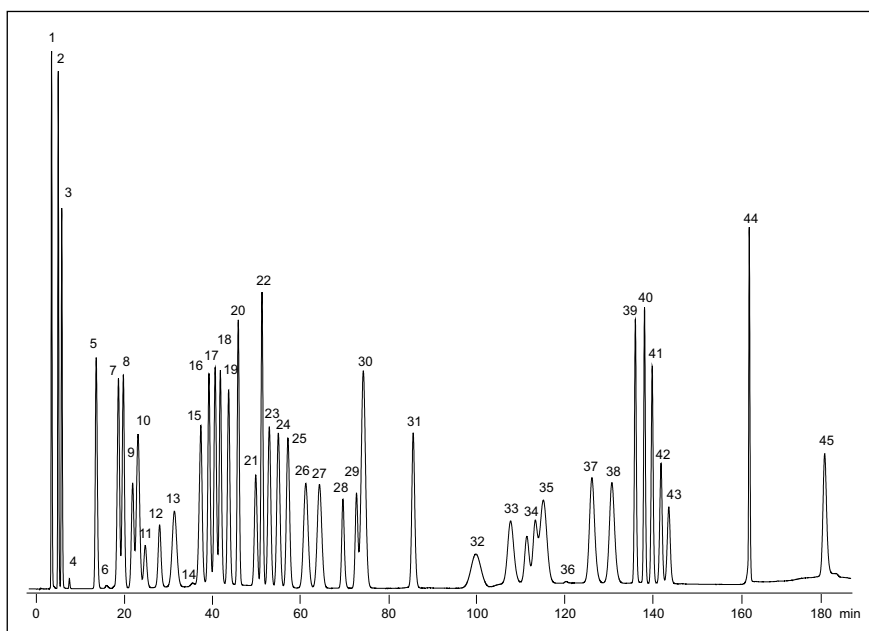
**PEAK IDENTIFICATION**

1. Phosphoserine	13. $\alpha$ -Amino adipic acid	25. Norleucine	37. Ornithine
2. Taurine	14. Proline	26. Tyrosine	38. Lysine
3. Phosphoethanolamine	15. Glycine	27. Phenylalanine	39. Histidine
4. Urea	16. Alanine	28. $\beta$ -Alanine	40. 3-Methylhistidine
5. Aspartic acid	17. Citrulline	29. $\beta$ -Amino- <i>i</i> -butyric acid	41. 1-Methylhistidine
6. Hydroxyproline	18. $\alpha$ -Amino- <i>n</i> -butyric acid	30. Homocystine	42. Carnosine
7. Threonine	19. Valine	31. $\gamma$ -Aminobutyric acid	43. Anserine
8. Serine	20. Cystine	32. Tryptophan	44. $\alpha$ -Amino- $\beta$ -guanidinopropionic acid
9. Asparagine	21. Methionine	33. Ethanolamine	45. Arginine
10. Glutamic acid	22. Cystathionine	34. Hydroxylysines	
11. Glutamine	23. Isoleucine	35. Ammonia	
12. Sarcosine	24. Leucine	36. Creatinine	

**METHOD 3: 0354100T PKU AND MSUD SCREENING LITHIUM (4.0 x 100mm)**

**GUARD COLUMN: GARD**

**COLUMN TEMP: 38°C**

**HPLC FLOW RATE: 0.35ml/min**

**REAGENT FLOW RATE: 0.3ml/min**

**INJECTION VOLUME: 10ul**

Time (min)	%Li275	%Li750	%RG003	Comment
0	86	14	0	Inject
25	73	27	0	Linear gradient
25.1	0	0	100	Step gradient
30	0	0	100	Isocratic
30.1	86	14	0	Step gradient
42	86	14	0	Re-equilibration

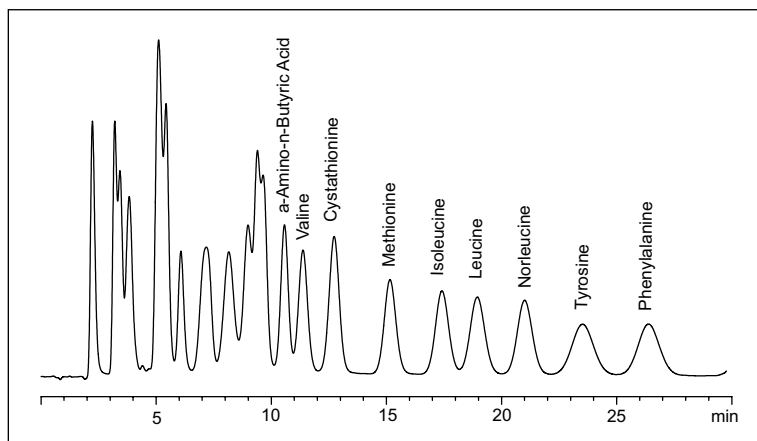



**METHOD 5: 1154150T ISOTHERMIC PROTEIN AND COLLAGEN HYDROLYSATE SODIUM (4.0 x 150mm)**  
**GUARD COLUMN: GARD**                      **COLUMN TEMP: 48°C**                      **HPLC FLOW RATE: 0.4ml/min**  
**REAGENT FLOW RATE: 0.3ml/min**                      **INJECTION VOLUME: 10ul**

CONDITIONS FOR PROTEIN & COLLAGEN HYDROLYSATE SAMPLES			
Time (Min)	Na315 %	Na740 %	RG011 %
0	100	0	0
10	100	0	0
30	0	100	0
53	0	100	0
53.1	0	0	100
55	0	0	100
55.1	100	0	0
67	100	0	0

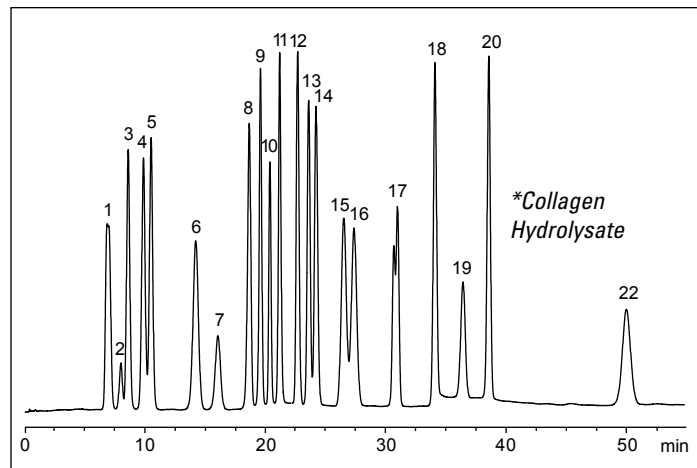
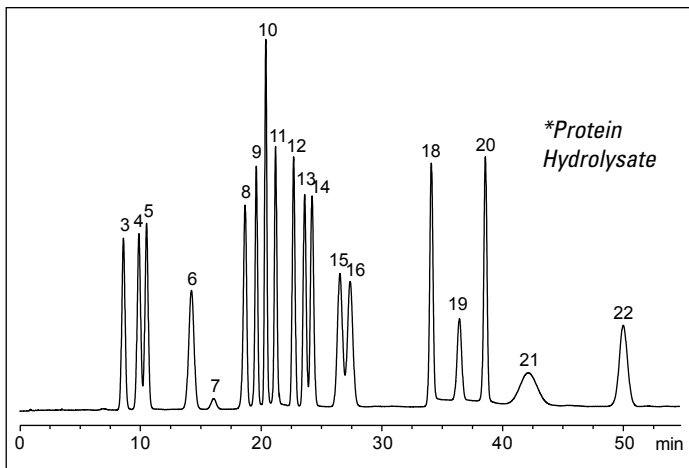

**PEAK IDENTIFICATION**

- |                             |                             |
|-----------------------------|-----------------------------|
| 1 Methionine-D,L,-Sulfoxide | 13 Isoleucine               |
| 2 trans-4-Hydroxy-L-Proline | 14 Leucine                  |
| 3 Aspartic Acid             | 15 Tyrosine                 |
| 4 Threonine                 | 16 Phenylalanine            |
| 5 Serine                    | 17 D,L & allo-Hydroxylysine |
| 6 Glutamic Acid             | 18 Lysine                   |
| 7 Proline                   | 19 Ammonia                  |
| 8 Glycine                   | 20 Histidine                |
| 9 Alanine                   | 21 Tryptophan               |
| 10 Cystine                  | 22 Arginine                 |
| 11 Valine                   |                             |
| 12 Methionine               |                             |

**METHOD 6: 1154150 ISOTHERMIC PROTEIN AND COLLAGEN HYDROLYSATE SODIUM (4.0 x 150mm)**  
**GUARD COLUMN: GARD**                      **COLUMN TEMP: 48°C**                      **HPLC FLOW RATE: 0.40ml/min**  
**REAGENT FLOW RATE: 0.3ml/min**                      **INJECTION VOLUME: 10ul**

Time(min)	%1700-0112*	%Na740	%RG011	Comment
0	100	0	0	inject
12	100	0	0	isocratic
34	0	100	0	linear gradient
53	0	100	0	isocratic
53.1	0	0	100	step gradient
55	0	0	100	isocratic
55.1	100	0	0	isocratic
67	100	0	0	re-equilibration

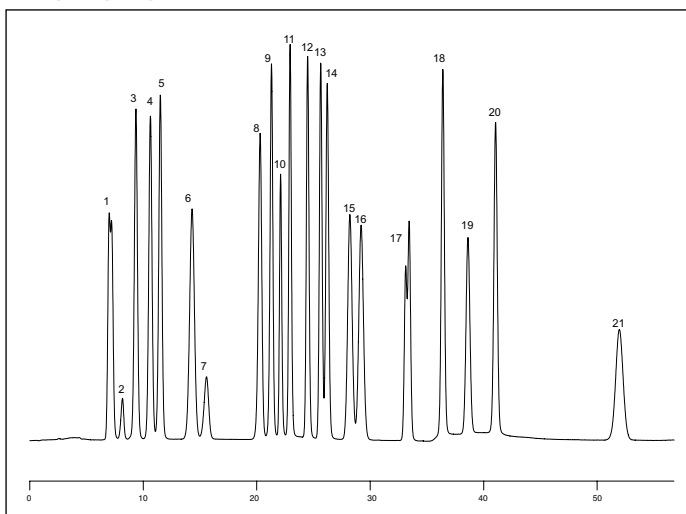
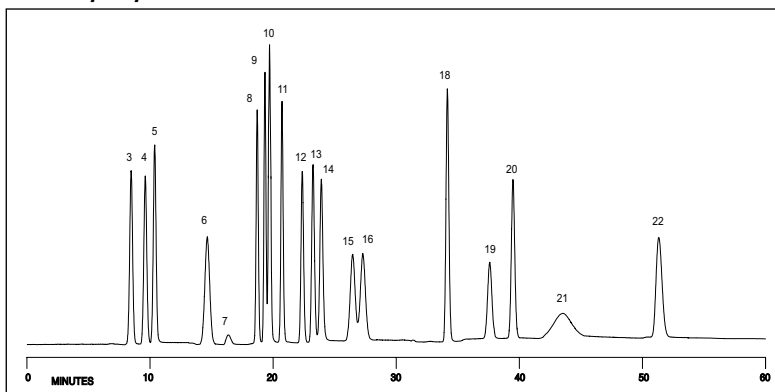
**Collagen Hydrolysate****Protein Hydrolysate**

\* For use with columns with serial numbers after 1314

**METHOD 7: 1193250 ISOTHERMIC PROTEIN HYDROLYSATE SODIUM (3.0 x 250mm)**

**GUARD COLUMN: GARD**

**COLUMN TEMP: 48°C**

**HPLC FLOW RATE: 0.30ml/min**

**REAGENT FLOW RATE: 0.3ml/min**

**INJECTION VOLUME: 10ul**

Time(min)	%Na328	%Na740	%RG011	Comment
0	100	0	0	inject
10	100	0	0	isocratic
32	0	100	0	linear gradient
56	0	100	0	isocratic
56.1	0	0	100	step gradient
58	0	0	100	isocratic
58.1	100	0	0	step change
70	100	0	0	re-equilibration

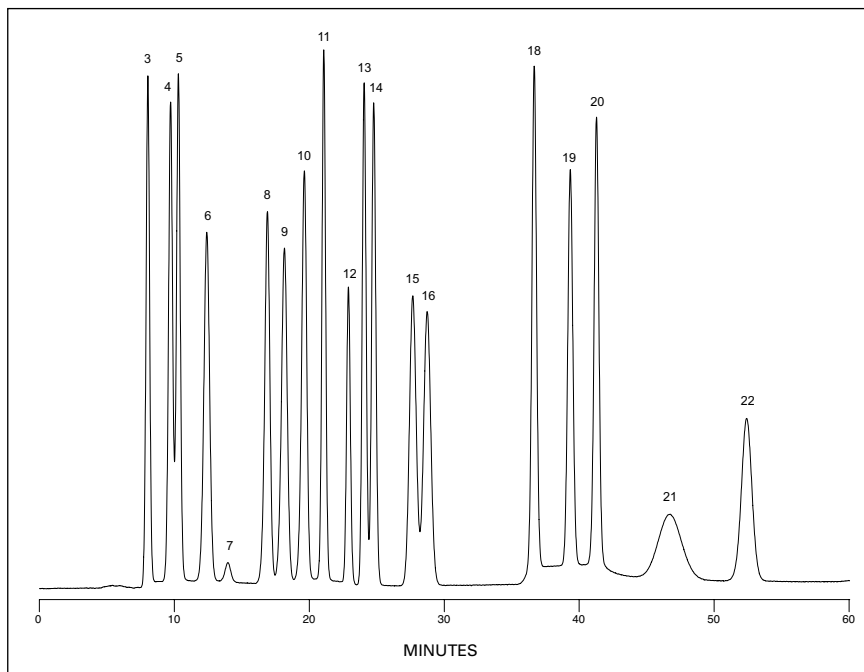

**PEAK IDENTIFICATION**

- |                         |                |                    |                        |
|-------------------------|----------------|--------------------|------------------------|
| 1. Methionine sulfoxide | 8. Glycine     | 15. Tyrosine       | 22. Arginine           |
| 2. Hydroxyproline       | 9. Alanine     | 16. Phenylalanine  | 23. Cysteic acid       |
| 3. Aspartic acid        | 10. Cystine    | 17. Hydroxylysines | 24. Methionine Sulfone |
| 4. Threonine            | 11. Valine     | 18. Lysine         | 25. Norleucine         |
| 5. Serine               | 12. Methionine | 19. Ammonia        |                        |
| 6. Glutamic acid        | 13. Isoleucine | 20. Histidine      |                        |
| 7. Proline              | 14. Leucine    | 21. Tryptophan     |                        |

---

## Precautions for Amino Acid Analysis

Use Pickering Laboratories reagents and eluants. The quality of the chemicals is excellent, and the cost is low relative to the worth of your analytical results.

Use the Pickering column and eluants. They are designed to work together.

Use the proper start-up and shutdown procedures consistently (see Chapter 2 and 4).

Avoid touching the interior of the mobile phase reservoirs and the dip tubes with your skin. Amino acids in fingerprints will cause contamination. Gloves are suggested.

When switching a system between ion-exchange and reversed-phase applications, be sure to flush the HPLC and injector with water before connecting the column. Eluants for one analysis may damage the column for the other.

Always protect the analytical column by use of the guard column. Always filter the samples through 0.45  $\mu$ m filter before injecting.

Daily check for leaks at the column fittings; the eluants can be corrosive.

Do not operate with a column pressure above 2800 psi (193 bars) for an extended period of time. Isolate the source of the high pressure—guard column, analytical column, or in-line filter (if in use) — and replace items causing the increased back pressure.

*Note:* Back-pressure from filter and guard column should be < 36 bars.

During shutdown, flush the column with regenerant for 15–20 min. Store the column in regenerant.

When removing the column, rinse the end-fittings with water then plug the column to prevent corrosion.

Contamination usually occurs on the guard column first. Wash it separately from the analytical column. This will save much time in the washing and re-equilibration.

Contaminants to be especially wary of: iron and other polyvalent cations, organic dyes, lipids, surfactants, and detergents. These may cause irreversible damage.

Organic solvents will cause the resin in the column to swell leading to high back-pressure and broadened peaks. The column sometimes can be regenerated.

---

Always wear gloves during the preparation of the reagents. The OPA and Thiofluor™ can cause skin irritation. Also fingerprints can cause contamination of the reagent. TRIONE® will stain skin.

The OPA reagent is sensitive to air oxidation, degrades over time, and should be prepared fresh for optimum sensitivity. OPA reagent is stable for at least one week when pressurized with inert gas.

Thiofluor™ is extremely hygroscopic. Always keep in a tightly closed container.

The preparation of the OPA Diluent by the user is not recommended because sodium borate (any grades) contains excessive amounts of heavy metal contaminants and insoluble matter. These impurities will eventually precipitate in the reactor and flowcell. The one year warranty does not cover damage caused by these contaminants.

The pre-mixed TRIONE® has a shelf life of 3 months\*. As it ages, the risk of precipitate formation increases. Using outdated TRIONE® is a major cause of clogging in post-column systems.

Never put new Trione in the bottle containing old reagent. This will cause premature aging of reagent. Always discard old reagent and clean the bottle before putting new TRIONE® in.

As TRIONE® ages, the color intensity for primary amines increases by up to 20%. A small drop in sensitivity when changing to a new lot of TRIONE® is not unusual.

Air oxidation of TRIONE® causes the intensity for primary amines to decrease, but does not affect the intensity for secondary amines. This makes secondary amines appear bigger. Also the reagent becomes more yellow when it is oxidized.

Frequently observe and record the pressures and check for leaks. You may find a problem before it becomes serious.

Do not operate the heated reactor above the boiling point of the eluant unless the back-pressure regulator is connected to the waste line of the detector. Boiling inside the reactor can cause precipitates to block the reactor. Operating above the boiling point without a back pressure regulator will void your warranty.

*Note:* Before making any change in the gradient, temperature, or other operating conditions, get at least two chromatograms in a row with the same problem. After you make a change, get at least two chromatograms showing the same effect of the change. This is especially true when you are trying to optimize gradient conditions.

---

Make only one small change at a time.

Make a change only after you have collected at least two chromatograms showing the same separation. This usually means three injections, as the first injection of a series rarely is representative of the rest of the series. Optimize the separations in the early part of the gradient before optimizing the late part.

Every model of HPLC forms gradients differently. The programs suggested in this manual or in the information sheets are typical of the more popular HPLC pumps. Consult Pickering Laboratories if you need advice. If you need only the early part of the chromatogram, you can save time by truncating the gradient. Go to the final concentration of regenerant and hold it until the most basic component (arginine) elutes, then re-equilibrate with the initial buffer.

The separation is temperature sensitive. Adjusting the temperature may improve it. For example, the resolution of threonine and serine improves when the column temperature is cooler, however the resolution of tyrosine and phenylalanine is best when the column temperature is warmer.

Surfactants, dyes, ninhydrin, and lipids usually cannot be removed. Prevention is the only cure.

*Section 7*  
**APPENDICES**

---

- 7.2** Installation/Operational Qualification of the Vector PCX
- 7.4** Installation/Operational Qualification of the Vector PCX Data Sheet
- 7.5** Vector Operational Qualification
- 7.6** Performance Qualification of the Vector PCX Data Sheet
- 7.12** Parts List for Vector PCX
- 7.13** References

## Installation/Operational Qualification of the Vector PCX

Installation Qualification Completed By: \_\_\_\_\_

Date: \_\_\_\_\_

Operational Qualification Completed By: \_\_\_\_\_

Date: \_\_\_\_\_

### 1.0 PURPOSE:

To qualify the installation and operation of the Vector PCX

### 2.0 REFERENCES:

- 2.1 Equipment Manual for the Vector PCX
- 2.2 Installation / Operational Qualification of the Vector PCX Data Sheet. Section 7.4 of the Operators Manual for the Vector PCX.

### 3.0 EQUIPMENT:

3.1 Installation / Operation Qualification

**Date**

**Initials**

Coordinator: \_\_\_\_\_

3.2 Equipment: \_\_\_\_\_

Asset #: \_\_\_\_\_

Serial #: \_\_\_\_\_

Location: \_\_\_\_\_

### 4.0 GENERAL INSTALLATION QUALIFICATIONS:

**Date**

**Initials**

4.1 Installation Site Requirements:

Space: 16.75 H x 8.75 W x 14.75 D inches (43 x 22 x 38 cm)

Electrical: 120 or 240 V

Weight: 26 lbs (11.6 kg) for Dual-pump systems

Gas: Nitrogen or Helium

4.2 Vector Installation Qualification:

4.2.1 Follow Section 3 in the Operators Manual for the Vector PCX for installation details of the Vector PCX.

4.2.2 Complete the Installation Qualification Check List in the Installation Operation / Qualification of the Vector PCX Data Sheet, Section 7.5 of the Operators Manual for the Vector PCX.

### 5.0 OPERATION QUALIFICATION:

**Date**

**Initials**

#### 5.1 Pump Flow Rate Accuracy

5.1.1 Turn on the Vector PCX.

5.1.2 Remove the Reagent 1 outlet to Mixing Manifold 1 and put a plug in its place into mixing manifold 1. Remove the Reagent 2 outlet to Mixing Manifold 2 and put a plug in its place. This isolates the Reagent Pumps from the flow path and ensures nothing leaks out of the mixing manifolds while the pumps are being qualified.

5.1.3 Enable the Vector PCX by starting the flow on the HPLC set to the desired flow rate for your application. The Enable Light will turn on when column pressure  $\geq$  425 psi. Press the Enable Button.

5.1.4 Set the Heated Reactor Temperature to 30 °C. This is to ensure the heated reactor stays cool.

- 5.1.5 Fill the reagent and piston wash bottles with 80/20 Water/Methanol. Tightly close the cap of the reagent bottle.
- 5.1.6 Follow Section 3.7 of the Operators Manual for the Vector PCX to properly prime the pumps.
- 5.1.7 Connect the outlet of Pump 1 to the 1000 psi back pressure regulator (PN 3102-9010) and then to the inlet of your Flow Meter. Set the flow rate for Pump 1 to 0.3 mL/min.
- 5.1.8 Allow a few minutes for the pump pressure to stabilize before recording the flow rate.
- 5.1.9 Repeat steps 5.1.7 to 5.1.8 with flow rates of 0.5, 1.0, and 2.0 mL/min.
- 5.1.10 Repeat steps 5.1.7 to 5.1.9 for Pump 2.

**5.2 Heated Reactor Accuracy**

- 5.2.1 Reconnect the Reagent Pump outlets and connect them to the appropriate Mixing Manifolds.
- 5.2.2 Set the flow rate of both pumps to 0.5 mL/min.
- 5.2.3 Remove the Vector cover and place a temperature probe in the hole on top of the Heated Reactor box.
- 5.2.4 Set the Heated Reactor set point to 36 °C. Allow 30 minutes for the Heated Reactor to equilibrate to the desired temperature.
- 5.2.5 Take three temperature readings five minutes apart.
- 5.2.6 Repeat steps 5.2.4 to 5.2.5 at a set point of 100 °C.  
Does the equipment operate properly? YES / NO

**5.3 Comments:** \_\_\_\_\_  
 \_\_\_\_\_  
 \_\_\_\_\_  
 \_\_\_\_\_

**6.0 MAINTENANCE PROCEDURES:**

**Date**                      **Initials**

6.1 Are maintenance procedures (per Section 4 of the Operators Manual for the Vector PCX) scheduled as part of the Preventative Maintenance System? YES / NO                      \_\_\_\_\_

6.2 Is an Equipment Activity Log available? YES / NO                      \_\_\_\_\_

**7.0 INSTALLATION / QUALIFICATION ACCEPTANCE:**

7.1 Criteria:

The equipment, as described in Section 3.2, will be successfully installed and qualified if all equipment components are in place and operating within the parameters and specifications originally set forth above. Any deviations or changes will be noted with justification in the Section 5.3, Comments.

7.2 Approvals:

**7.2.1 Installation/Operation Qualification:**

These signatures verify that the equipment, as described in Section 4.2, meets the criteria for proper Installation/Operation Qualification.

Approved by (Quality): \_\_\_\_\_ Date: \_\_\_\_\_

Approved by (Management): \_\_\_\_\_ Date: \_\_\_\_\_

---

### Installation/Operational Qualification of the Vector PCX Data Sheet

Serial Number:

Customer:

120V or 240V

Asset:

#### Installation Qualification Check List

Are all of the contents listed on the packing list present?	Yes / No
Is there enough bench space between the HPLC and the detector?	Yes / No
Is there at least 3 inches behind the Vector PCX for ventilation?	Yes / No
Is there any damage on the outside of the Vector PCX?	Yes / No
Is there any damage inside the Vector PCX?	Yes / No
Are all electrical connections secured?	Yes / No
Is the gas source regulator set to a maximum of 75 psi?	Yes / No
Is a waste bottle provided by the user?	Yes / No
Is the HPLC correctly deadheaded? Refer to Section 3.4 or the Operators Manual for the Vector PCX.	Yes / No
Does the Power On lamp turn on when the Vector PCX is powered on?	Yes / No
Does the Enable Light Turn on at column pressure $\geq$ 425 psi?	Yes / No
Enable the instrument by pressing the Enable button when the Enable Light turns on. Are you able to turn on the pumps?	Yes / No
Does the gas toggle valve turn the gas on and off?	Yes / No

---

## Vector Operational Qualification

Serial Number:

Customer:

120V or 240V

Asset:

### Flow Rate Accuracy

#### Pump 1

Flowrate Setpoint in mL/min	Record Flowrate in ml/min	Specifications @ 1000psi	Pass / Fail
0.3		+/- 0.009 ml/min	
0.5		+/- 0.015 ml/min	
1.0		+/- 0.030 ml/min	
2.0		+/- 0.060 ml/min	

#### Pump 2

Flowrate Setpoint in mL/min	Record Flowrate in ml/min	Specifications @ 1000psi	Pass / Fail
0.3		+/- 0.009 ml/min	
0.5		+/- 0.015 ml/min	
1.0		+/- 0.030 ml/min	
2.0		+/- 0.060 ml/min	

### Heated Reactor Accuracy

Heated Reactor Part Number:

Temperature Setpoint in °C	Temperature Reading in °C	Average Reading	Specifications	Pass / Fail
36.0			+/- 1.0 °C	
36.0				
36.0				
100.0			+/- 1.0 °C	
100.0				
100.0				

Comments:

Performed By:

Date Performed:

Reviewed By:

Date Reviewed:

Next Due Date:

## Performance Qualification of the Vector PCX Data Sheet

Serial Number: \_\_\_\_\_ Customer: \_\_\_\_\_  
 120V or 240V \_\_\_\_\_ Asset: \_\_\_\_\_

### Glyphosate Application

Glyphosate Column Part Number: \_\_\_\_\_ Serial Number: \_\_\_\_\_  
 Glyphosate Guard column Part Number: \_\_\_\_\_  
 Glyphosate Test Mixture (p/n 1700-0080) Lot Number: \_\_\_\_\_  
 Thiofluor (p/n 3700-2000) Lot Number: \_\_\_\_\_  
 o-phthalaldehyde (p/n O120) Lot Number: \_\_\_\_\_  
 Glyphosate OPA Diluent (p/n GA104) Lot Number: \_\_\_\_\_ Expiration Date: \_\_\_\_\_  
 Glyphosate Hypochlorite Diluent (p/n GA116) Lot Number: \_\_\_\_\_ Expiration Date: \_\_\_\_\_  
 Glyphosate Potassium Eluant (p/n K200) Lot Number: \_\_\_\_\_ Expiration Date: \_\_\_\_\_  
 Glyphosate Column Regenerant (p/n RG019) Lot Number: \_\_\_\_\_ Expiration Date: \_\_\_\_\_

Glyphosate	Retention Time in min	Average Retention Time	Standard Deviation	% CV	Specification	Pass / Fail
Run 1					≤ 0.5%	
Run 2						
Run 3						
Run 4						
Run 5						
Run 6						

Glyphosate	Peak Area	Average Peak Area	Standard Deviation	% CV	Specification	Pass / Fail
Run 1					≤ 1.5%	
Run 2						
Run 3						
Run 4						
Run 5						
Run 6						

**Carbamate Application**

Carbamate Column Part Number: \_\_\_\_\_ Serial Number: \_\_\_\_\_

Carbamate Guard column Part Number: \_\_\_\_\_

Carbamate Test Mixture (p/n 1700-0063) Lot Number: \_\_\_\_\_

Thiofluor (p/n 3700-2000) Lot Number: \_\_\_\_\_

o-phthalaldehyde (p/n O120) Lot Number: \_\_\_\_\_

Carbamate OPA Diluent (p/n CB910) Lot Number: \_\_\_\_\_ Expiration Date: \_\_\_\_\_

Carbamate Hydrolysis Reagent (p/n "CB130 or CB130.2) Lot Number: \_\_\_\_\_ Expiration Date: \_\_\_\_\_

Aldicarb sulfoxide	Retention Time in min	Average Retention Time	Standard Deviation	% CV	Specification	Pass / Fail
Run 1					≤ 0.5%	
Run 2						
Run 3						
Run 4						
Run 5						
Run 6						

Aldicarb	Retention Time in min	Average Retention Time	Standard Deviation	% CV	Specification	Pass / Fail
Run 1					≤ 0.5%	
Run 2						
Run 3						
Run 4						
Run 5						
Run 6						

Aldicarb sulfoxide	Peak Area	Average Peak Area	Standard Deviation	% CV	Specification	Pass / Fail
Run 1					≤ 1.5%	
Run 2						
Run 3						
Run 4						
Run 5						
Run 6						

Aldicarb	Peak Area	Average Peak Area	Standard Deviation	% CV	Specification	Pass / Fail
Run 1					≤ 1.5%	
Run 2						
Run 3						
Run 4						
Run 5						
Run 6						

**Sodium Amino Acids Application**

Amino Acid Column Part Number:	1154150	Serial Number:	
Guard column Part Number:	1193020		
Test Mixture (p/n 1700-0070)		Lot Number:	
Trione (T100 or T200):		Lot Number:	
Na Eluant (p/n 1700-0112)		Lot Number:	Expiration Date:
Na Column Reagent (p/n RG011)		Lot Number:	Expiration Date:

Threonine	Retention Time in min	Average Retention Time	Standard Deviation	% CV	Specification	Pass / Fail
Run 1					≤ 0.5%	
Run 2						
Run 3						
Run 4						
Run 5						
Run 6						

Serine	Retention Time in min	Average Retention Time	Standard Deviation	% CV	Specification	Pass / Fail
Run 1					≤ 0.5%	
Run 2						
Run 3						
Run 4						
Run 5						
Run 6						

Cysteic Acid	Retention Time in min	Average Retention Time	Standard Deviation	% CV	Specification	Pass / Fail
Run 1					≤ 0.5%	
Run 2						
Run 3						
Run 4						
Run 5						
Run 6						

**Sodium Amino Acids Application, continued**

Threonine	Peak Area	Average Peak Area	Standard Deviation	% CV	Specification	Pass / Fail
Run 1					≤ 1.5%	
Run 2						
Run 3						
Run 4						
Run 5						
Run 6						

Serine	Peak Area	Average Peak Area	Standard Deviation	% CV	Specification	Pass / Fail
Run 1					≤ 1.5%	
Run 2						
Run 3						
Run 4						
Run 5						
Run 6						

Cysteic Acid	Peak Area	Average Peak Area	Standard Deviation	% CV	Specification	Pass / Fail
Run 1					≤ 1.5%	
Run 2						
Run 3						
Run 4						
Run 5						
Run 6						

**Lithium Amino Acids Application**

Amino Acid Column Part Number: Serial Number:

Guard column Part Number:

Test Mixture (p/n 1700-0070) Lot Number:

Trione (T100 or T200): Lot Number:

Li Eluant Buffer A: Lot Number: Expiration Date:

Li Column Reagent (p/n RG003) Lot Number: Expiration Date:

Threonine	Retention Time in min	Average Retention Time	Standard Deviation	% CV	Specification	Pass / Fail
Run 1					≤ 0.5%	
Run 2						
Run 3						
Run 4						
Run 5						
Run 6						

Serine	Retention Time in min	Average Retention Time	Standard Deviation	% CV	Specification	Pass / Fail
Run 1					≤ 0.5%	
Run 2						
Run 3						
Run 4						
Run 5						
Run 6						

Cysteic Acid	Retention Time in min	Average Retention Time	Standard Deviation	% CV	Specification	Pass / Fail
Run 1					≤ 0.5%	
Run 2						
Run 3						
Run 4						
Run 5						
Run 6						

Threonine	Peak Area	Average Peak Area	Standard Deviation	% CV	Specification	Pass / Fail
Run 1					≤ 1.5%	
Run 2						
Run 3						
Run 4						
Run 5						
Run 6						

Serine	Peak Area	Average Peak Area	Standard Deviation	% CV	Specification	Pass / Fail
Run 1					≤ 1.5%	
Run 2						
Run 3						
Run 4						
Run 5						
Run 6						

Cysteic Acid	Peak Area	Average Peak Area	Standard Deviation	% CV	Specification	Pass / Fail
Run 1					≤ 1.5%	
Run 2						
Run 3						
Run 4						
Run 5						
Run 6						

**Method Table**

Time	Buffer A*	RG003
0	100	0
20	100	0
20.1	0	100
24	0	100
24.1	100	0
Stop Time	24 min	
Post Time	12 min	

Column Temp: Refer to column insert.  
 Eluant Flow Rate: Refer to column insert.  
 Reactor Temperature: 130 deg C  
 Reagent Flow Rate: 0.3mL/min

\* Use the A Buffer corresponding to the column you have. The column insert will have the correct initial buffer listed in the method.

## Parts List for Vector PCX

### VECTOR PCX REAGENT PUMP COMPONENTS

CATALOG NO.	DESCRIPTION
3106-1254	Pump Check Valve Kit – PEEK (Inlet & Outlet)
3106-1255	Seal Kit, 10 mL (Piston seal, Back-up O-ring, Diaphragm, Tool)
3106-1256	Pulse Damper Rebuild Kit (Diaphragm, O-rings, Diaphragm seal, Seal tool, 4 Hex wrenches)
3106-1258	Prime/Purge Valve - PEEK
3106-1259	Head Kit, Vector Pump, (head, check valves, piston and seal)
3106-1257	Piston, Vector Pump, 10 mL
1452-0176	Ferrule, PEEK 1/16 x 10-32 S/T, 5 each
1452-0177	Nut, PEEK Long 1/16 x 10-32 S/T, 5 each
3106-1260	Prime Purge Seal Kit – PEEK
3102-9040	10um reagent filter, PEEK
3102-9042	0.5um filter. Before flow restrictor

### VECTOR PCX SUBSTITUTE REACTOR VOLUMES OR REPLACEMENT REACTORS

CATALOG NO.	DESCRIPTION
1452-0162	Reactor Heater & Coil Assembly, 0.5mL 150°C max, 120V
1452-0163	Reactor Heater & Coil Assembly, 0.5mL 150°C max, 240V
1452-0164	Reactor Heater & Coil Assembly, 1.0mL 150°C max, 120V
1452-0165	Reactor Heater & Coil Assembly, 1.0mL 150°C max, 240V
1452-0166	Reactor Heater & Coil Assembly, 1.4mL 150°C max, 120V
1452-0167	Reactor Heater & Coil Assembly, 1.4mL 150°C max, 240V
1452-0174	Reactor Heater & Knitted Coil Assembly, 1.2 & 1.6mL 150°C max, 120V
1452-0175	Reactor Heater & Knitted Coil Assembly, 1.2 & 1.6mL 150°C max, 240V
1100-2927	OPA Ambient Reactor, 0.011 in ID TFE Tubing
1100-0282	Coil Assembly, 0.15 mL without Electronics
1100-0281	Coil Assembly, 0.5 mL without Electronics
1100-0283	Coil Assembly, 1.0 mL without Electronics
1100-0284	Coil Assembly, 1.4 mL without Electronics

*Note: Custom volumes are available*

---

## References

### INSTRUMENTATION

- M.V. Pickering, "Assembling an HPLC post-column system: practical considerations," *LC•GC*, 6, 11 (1988) 994–997.\*
- M.V. Pickering, "Modifying HPLC equipment to tolerate corrosive solutions," *LC•GC*, 6, 9 (1988) 800–809.\*
- J.W. Dolan and L.R. Snyder, "Troubleshooting LC Systems," Humana Press, Clifton, NJ (1989).

\* Reprints available from Pickering Laboratories

### AMINO ACID ANALYSIS

- D.H. Spackman, W.H. Stein and S. Moore, *Anal. Chem.*, 30 (1958) 1190.
- M. V. Pickering, *LC•GC*, 7 (1988) 484.\*
- J. A. Grunau and J.M. Swiader, *J. Chromatogr.*, 594 (1992) 165.\*
- A. A. Boulton, G. B. Baker and J.D. Wood (Eds.), "Neuromethods 3, Amino Acids," Humana Press, Clifton, NJ (1985), Chapter 1.

### CARBAMATES ANALYSIS

- "Measurement of N-methyl carbamoyloximes and N-methyl carbamates in drinking water by direct aqueous injection LC with post-column derivatization," EPA Method 531 by D.L. Foerst, EPA/600/4-851054 (1986); Method 5, revised by T. Engels, National Pesticide Survey, Battelle Columbus Lab (1987); Method 531.1, revised by R.L. Graves, EPA, Environmental Monitoring and Support Laboratory, Cincinnati (1989).
- M. W. Dong, F.L. Vandemark, W.M. Reuter, and M.V. Pickering, "Carbamate pesticides analysis by liquid chromatography," *Amer. Environ. Lab.*, 2(3) (1991) 14–27.
- K.M. Hill, R.H. Hollowell, and L. D. Dal Cortivo, "Determination of N-methylcarbamate pesticides in well water by liquid chromatography with post-column fluorescence derivatization," *Anal. Chem.*, 56 (1984) 2465–2475.
- H. Frister, H. Meisel, and E. Schlimme, "OPA Method Modified by Use of N,N-Dimethyl-2-mercaptoethylammonium Chloride," *Fresenius Z. Anal. Chem.*, 330 (1988) 631–633.

### GLYPHOSATE ANALYSIS

- J.E. Cowell, "Analytical Residue Method for N-Phosphono-methylglycine and Aminomethylphosphonic acid in Environmental Water," Monsanto Method Number 86-63-1, 1987
- Environmental Protection Agency Draft Method 597: "Analysis of Glyphosate in Drinking Water by Direct Aqueous Injection LC with Post-Column Derivatization."

# INDEX

---

- A** Air Barrier Tubing 3, 2.9, 2.12, 3.2, 3.6, 3.7, 4.1  
Ambient Reactor 2.2, 2.8, 2.9, 2.10, 2.12, 3.6  
Amino Acid 7.10  
Amino Acids 6.1, 6.3, 6.3-1, 6.3-2, 6.3-3, 6.3-5, 6.3-13, 7.8, 7.9, 7.13  
AMPA 5.6, 6.2, 6.2-1, 6.2-3, 6.2-5, 6.2-6  
AOAC Method 6.1-3, 6.3-2  
Autosampler 6.3
- B** Back Pressure Regulator 2.10, 3.6, 5.3, 6.3-14  
Baseline Noise 2, 5.4  
Boiling 2.10, 6.3-14  
Buffer 6.3-3, 6.3-15, 7.10, 7.11
- C** Calcium Hypochlorite 6.2-3  
Cap 6.3-3, 6.3-4  
Carbamates 2.12, 3.5, 5.6, 6.1, 6.1-1, 6.1-2, 6.1-3, 6.1-4, 6.1-10, 6.1-11, 7.13  
Check Valve 2.7, 2.8, 2.9, 3.6, 4.1, 4.2, 4.3, 4.4, 4.5, 4.6, 5.3, 5.4, 5.6, 7.12  
ChlorAC Buffer 6.1-4  
Collagen Hydrolysate 6.3-10, 6.3-11  
Column Oven 6.3-5  
Column Pressure 6.3-13  
Column Temperature 6.3-15  
Contaminants 6.3-14  
Contamination 6.3-13, 6.3-14
- D** Dead-Head 5  
Designing a Post-Column System 1, 5  
Design of an HPLC System 1, 3  
Detector Connections 2.1, 2.10, 3.1, 3.5  
Diaphragm 2.7, 2.11, 4.2, 4.4, 5.6, 7.12  
Display Panel 2.1, 2.9
- E** Electrical 1, 3, 4, 2.10, 2.11, 4.1, 5.1, 7.2, 7.4  
Eluant 6.3, 6.3-13, 6.3-14, 7.10, 7.11  
EPA Method 531.2 6.1-11  
Equilibration 6.3-6, 6.3-7, 6.3-8, 6.3-11, 6.3-12, 6.3-13
- F** Filter 2.2, 2.8, 2.10, 2.12, 4.1, 4.7, 4.9, 5.4, 5.5, 6.1-4, 6.1-11, 6.2-2, 6.2-7, 7.12  
Fittings 6.3-13  
Flow Path 2.1, 2.3, 3.2, 5.3, 5.5, 5.7, 7.2  
Fuse 3, 2.12, 4.1, 4.8
- G** Gas Connection 3.1, 3.6  
Gas Manifold 2.2, 2.9, 3.6  
Glyphosate 4, 5, 2.12, 3.2, 3.9, 5.1, 5.5, 5.6, 5.8, 6.1, 6.2, 6.2-1, 6.2-2, 6.2-3, 6.2-4, 6.2-5, 6.2-6, 6.2-7, 7.6, 7.13  
Grease 4.6, 5.1, 5.6, 5.8

# INDEX

---

- H** Heated Reactor 3, 2.2, 2.8, 2.9, 2.10, 2.11, 2.12, 3.8, 3.10, 4.1, 4.7, 4.8, 4.9, 5.3, 5.6, 6.3-14, 7.2, 7.3, 7.5  
High Pressure 6.3-13  
Hydrindantin 6.3-1  
Hydrolysis Reagent 5, 5.4, 6.1-4, 6.1-5, 6.1-6, 7.7
- I** Inert Gas 2.9, 2.10, 3.6, 3.10, 6.1-4, 6.1-5, 6.1-10, 6.1-11, 6.2-3, 6.2-6, 6.3-4, 6.3-14  
Ion-exchange 6.3, 6.3-1, 6.3-13  
Ion-exclusion 6.3-1
- L** Leaks 6.3-13, 6.3-14  
Lithium ion-exchange 6.3
- M** Main Power 2.12  
MSDS 3.1, 4.1  
MSUD 6.3-8
- N** Ninhydrin 6.3, 6.3-1, 6.3-2, 6.3-4, 6.3-15  
Nitrogen 4, 3.2, 7.2
- O** OPA 5, 3.2, 3.10, 5.4, 6.1-1, 6.1-3, 6.1-5, 6.1-10, 6.1-11, 6.2-1, 6.2-3, 6.2-6, 6.3, 6.3-2, 6.3-4, 6.3-5, 6.3-14, 7.6, 7.7, 7.12, 7.13  
OPA Diluent 6.1-5, 6.1-11, 6.2-3, 6.2-6  
o-phthalaldehyde 5, 6.1-3, 6.1-4, 6.1-6, 6.2-1, 6.2-4  
Organic Solvents 6.3-13  
Over-Pressure Relief 2.12, 3.1, 3.9, 5.3, 5.7
- P** Peak Identification 6.3-6, 6.3-7, 6.3-9, 6.3-10, 6.3-12  
Peaks disappear 5.4  
Peak Shape 2, 5.5  
PEEK fitting 5.6  
Physiological Fluid 6.3-2, 6.3-6, 6.3-7  
Piston-Wash 2.7  
PKU 6.3-8  
Post Column Conditions 6.3-4  
Post-Column Derivatization 1, 1, 2, 6.1-1, 6.2, 6.3, 7.13  
Precautions 6.3, 6.3-13  
Precipitate 6.3-14  
Precipitation 6.1-11  
Pre-column filter 5.5  
Primary Amines 6.3-1, 6.3-2, 6.3-14  
Protein Hydrolysate 6.3, 6.3-2, 6.3-11, 6.3-12

# INDEX

---

- R** Reactor Temperature 7.11  
Reagent Filter 2.2, 2.8, 4.1, 4.7, 4.9, 7.12  
Reagent Preparation 6.3-3  
Reagent Pressure 4.7, 4.9, 5.3  
Reagent Pump 2, 3, 1, 2, 5, 2.1, 2.7, 2.8, 2.9, 2.10, 2.11, 2.12, 3.1, 3.6, 3.7, 3.8, 3.9, 3.10, 4.7, 4.8, 4.9, 5.1, 5.3, 5.4, 5.6, 5.9, 7.2, 7.3, 7.12  
Reagent Reservoir 1, 4, 2.1, 2.9, 2.10, 2.12, 3.2, 3.3, 3.6, 4.1, 5.9, 6.1-5, 6.2-2, 6.2-3, 6.3-3, 6.3-4  
Regenerant 5, 3.9, 5.8, 6.3-13, 6.3-15, 7.6  
Restore 5.1, 5.6, 5.8, 5.9, 6.2-2  
Rotor Seal 4, 3.2, 5.4, 5.5
- S** Sample Chromatogram 6.3, 6.3-4  
Sample Preparation 6.3, 6.3-2  
Seals 2.8, 2.10, 4.1, 4.3, 4.4, 4.9, 5.6  
Secondary Amines 6.3-1, 6.3-2, 6.3-14  
SERAPREP 6.3-3  
Shelf Life 6.3-14  
Shutdown 3.1, 3.9, 3.10, 5.3, 5.5, 6.1-10, 6.2-6, 6.3-13  
Site Requirement 1, 4, 3.1, 7.2  
Sodium Hypochlorite 5, 6.2-2, 6.3-5  
Sodium ion-exchange 6.3  
Specifications 1, 2, 3, 3.8, 4.8, 5.2, 7.3, 7.5  
Standard Configurations 2.1, 2.12  
Standards 6.3  
Symbols and Safety Warning 1
- T** Technical Support 5.1, 5.5  
Tefzel 6.3  
Thiofluor 5, 6.1-3, 6.1-5, 6.1-6, 6.1-11, 6.2-1, 6.2-3, 6.2-4, 6.2-6, 6.3-2, 6.3-4, 6.3-5, 6.3-14, 7.6, 7.7  
Trione 6.3, 6.3-3, 6.3-4, 6.3-14, 7.10
- U** URIPREP 6.3-3
- W** Warranty 6.3-14  
Wetted Materials 3